

SAFALI: a New System for “In-Situ” Field Mapping of IDs

*Takashi TANAKA, Takamitsu SEIKE, Hideo KITAMURA
RIKEN SPring-8 Center*

- Field Mapping of IDs
- What is “In-Situ Mapping” and “SAFALI”?
- Principle of Operation
- Results of Measurements
- Outlook

Field Mapping of IDs (1)

- Measurement of field distribution $\mathbf{B}(r)$
- Usually done with Hall-effect sensors
- Necessary for field correction
 - Optical phase error
 - Integrated multipole components
- Undulator field with **shorter** λ_u is more sensitive to r



Reliable system for Hall sensor actuation is necessary!

Field Mapping of IDs (2)

Conventional Measurement System

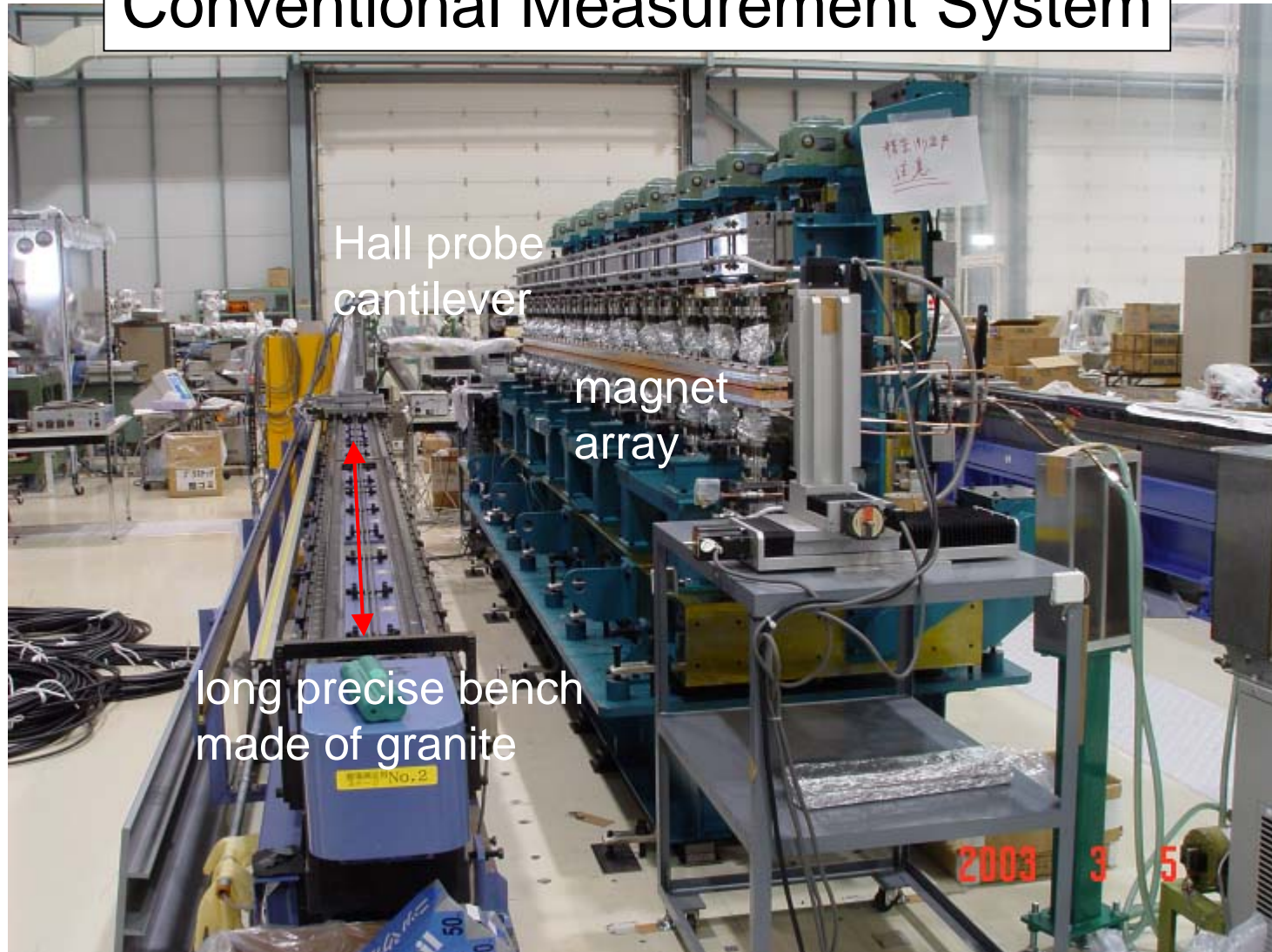

Field Mapping of IVUs (3)



Cross Section of
IVU Structure

- Field mapping of IVUs
 - **Conventional methods cannot be applied!**
 - Measurement w/o the vacuum chamber
 - Assembling after field correction

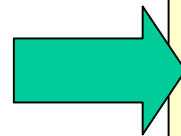

Rely on the mechanical accuracy to ensure the reproducibility of magnetic performance

“In-Situ” Field Mapping

- Field Mapping of IVU with the Vac. Chamber

- Undulators for SPring-8 XFEL

- **After assembly**

- **During FEL commissioning**

- **After long-term operation**

- “Cryogenic” Undulator

- **In the cryogenic environment**

“In-Situ”
Field Mapping

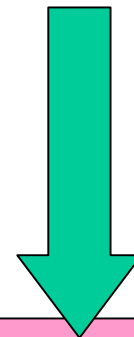

More compact & portable system is required.

SAFALI System: Principle

- Self-Aligned Field Analyzer with Laser Instrumentation
 - Simple system for Hall probe actuation (not necessarily rigid or robust)
 - Monitor the Hall probe position with laser beam and perform dynamic feedback
 - Longitudinal position reading with a laser scale

SAFALI System for IVU

Top View

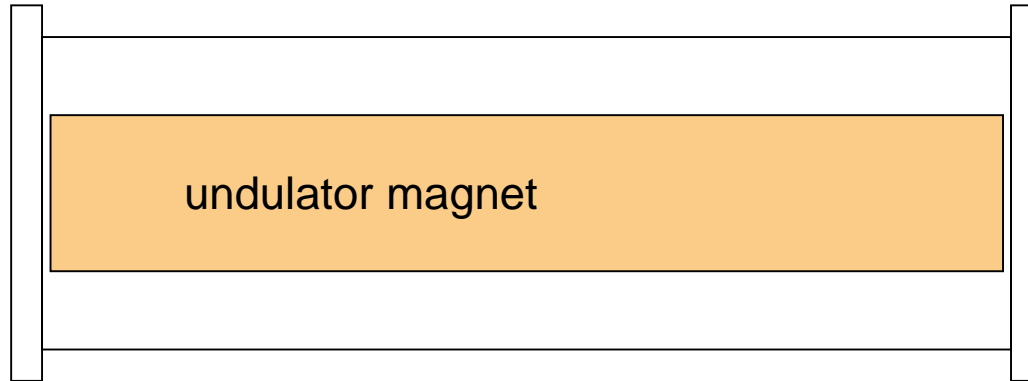

Side View

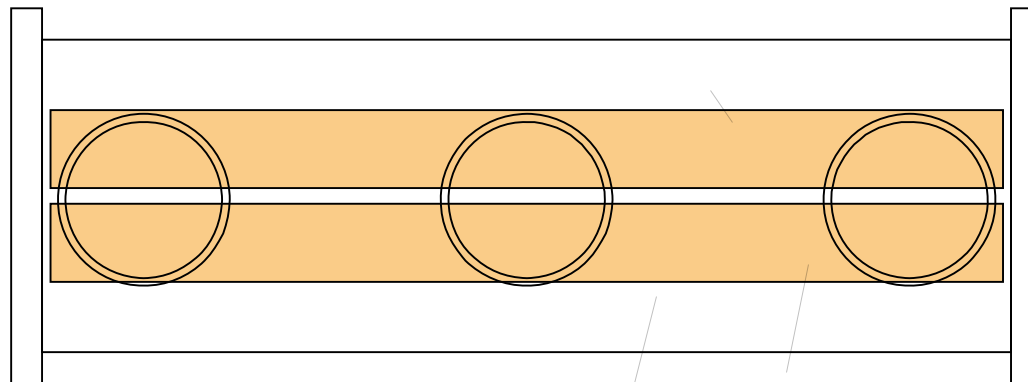

SAFALI System for IVU

Top View

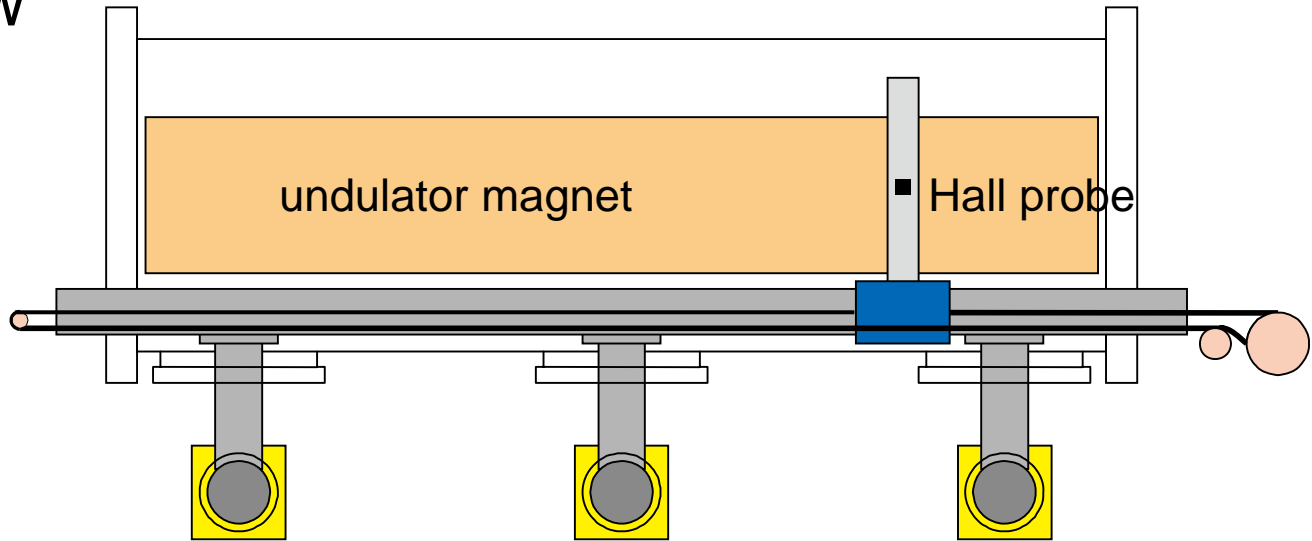

Side View

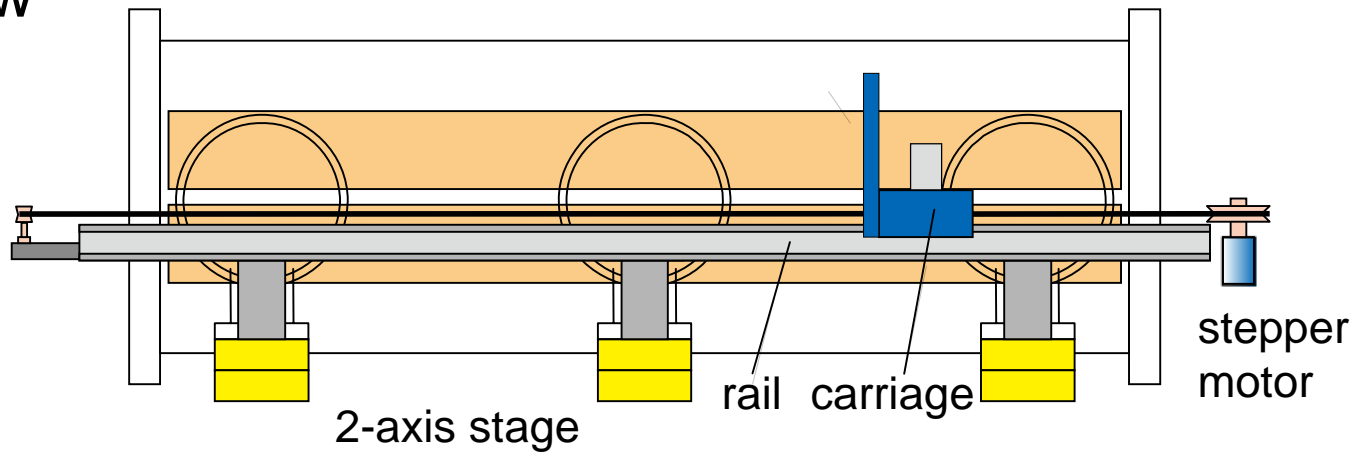

SAFALI System for IVU

Top View

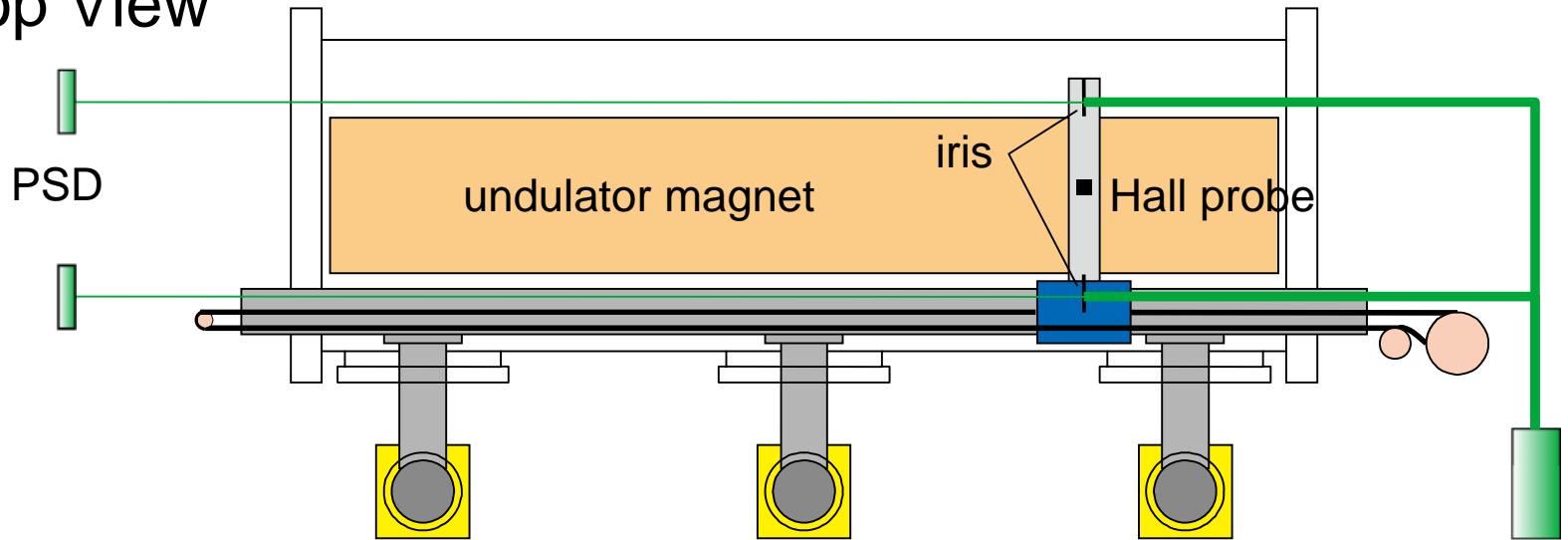

Side View

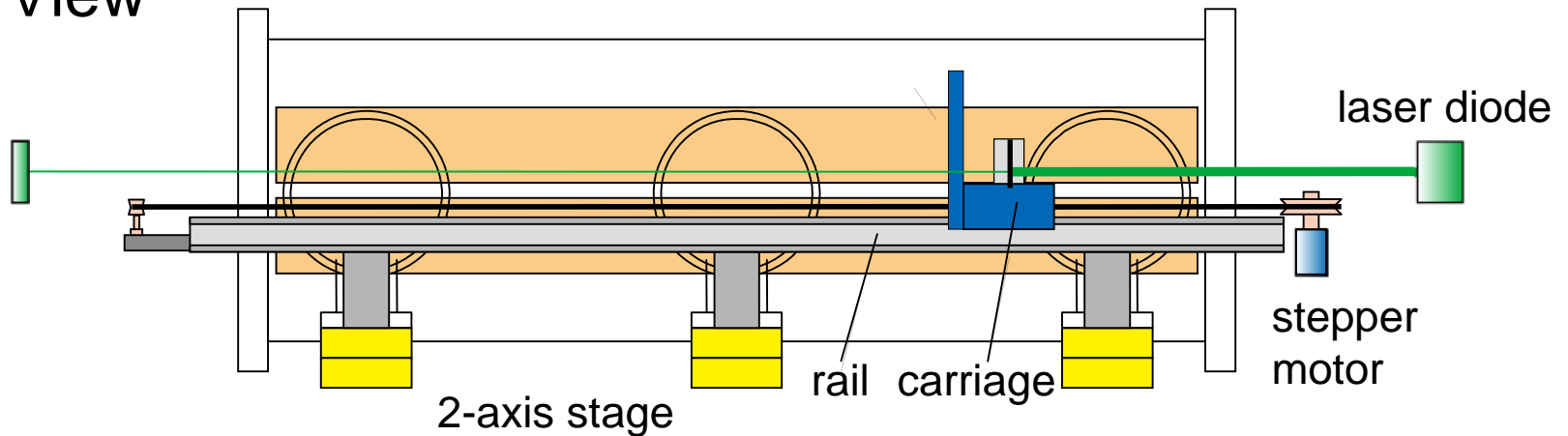

SAFALI System for IVU

Top View

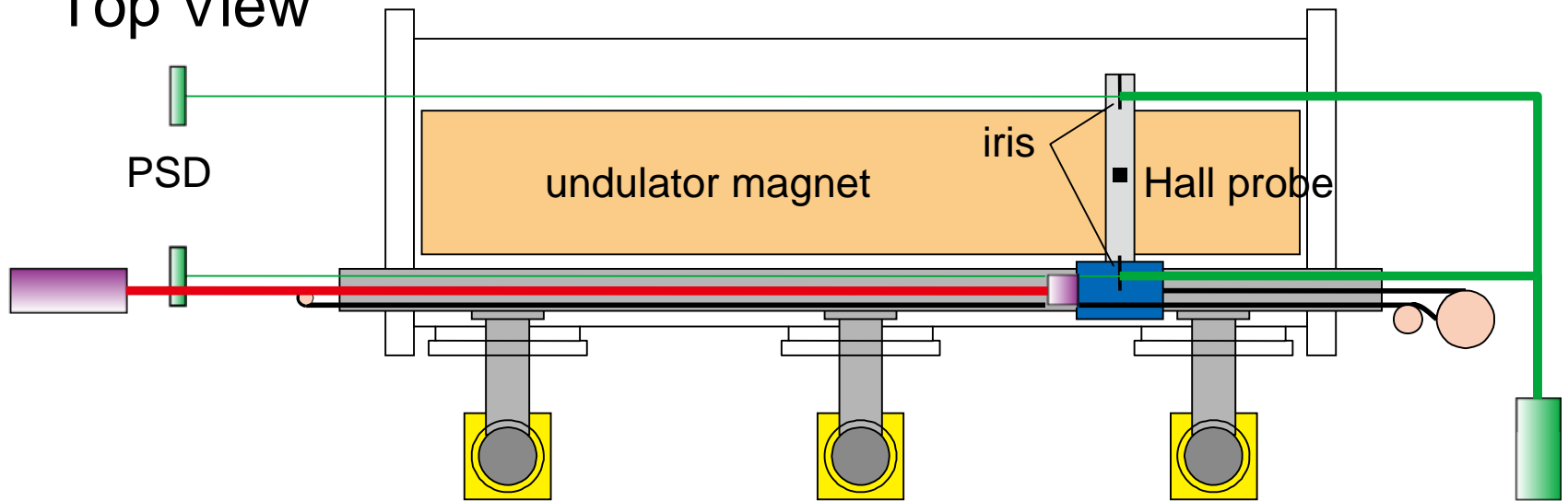

Side View

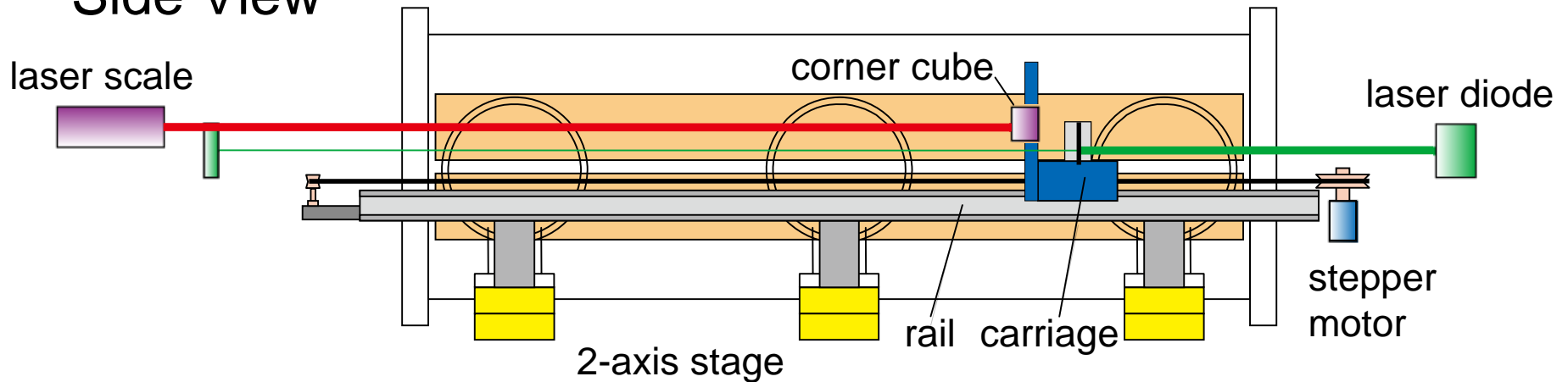

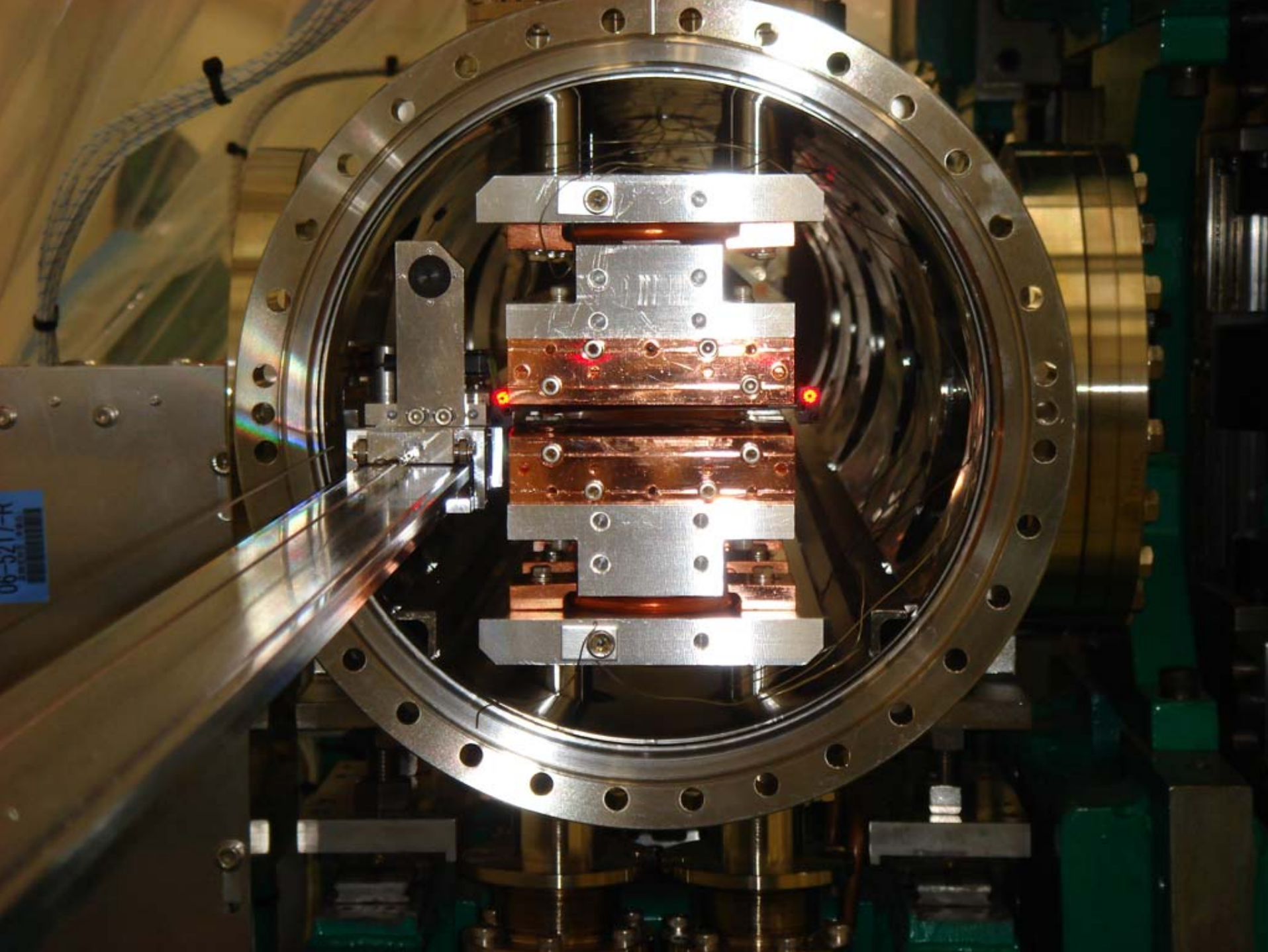

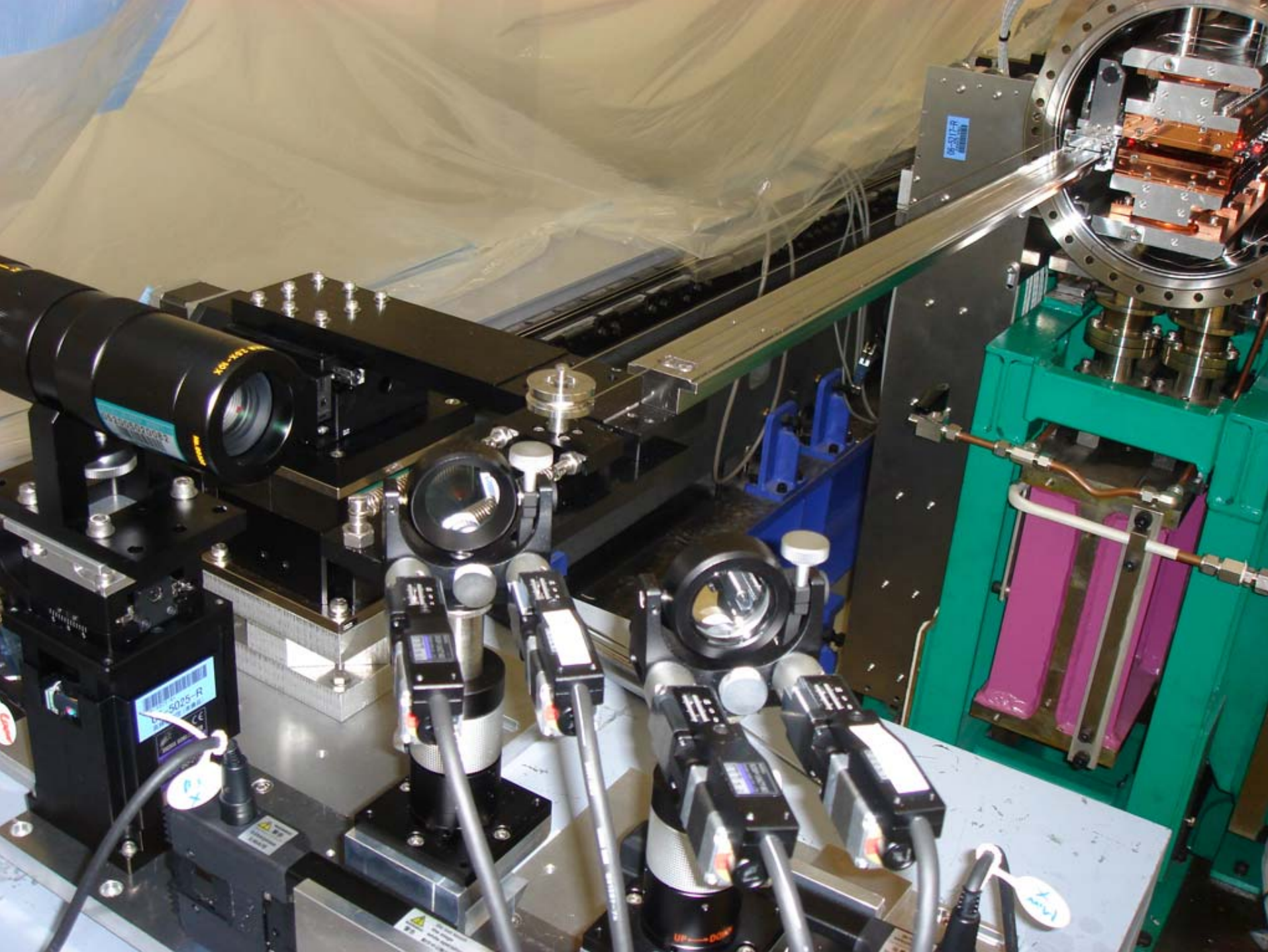



Example of Position Feedback

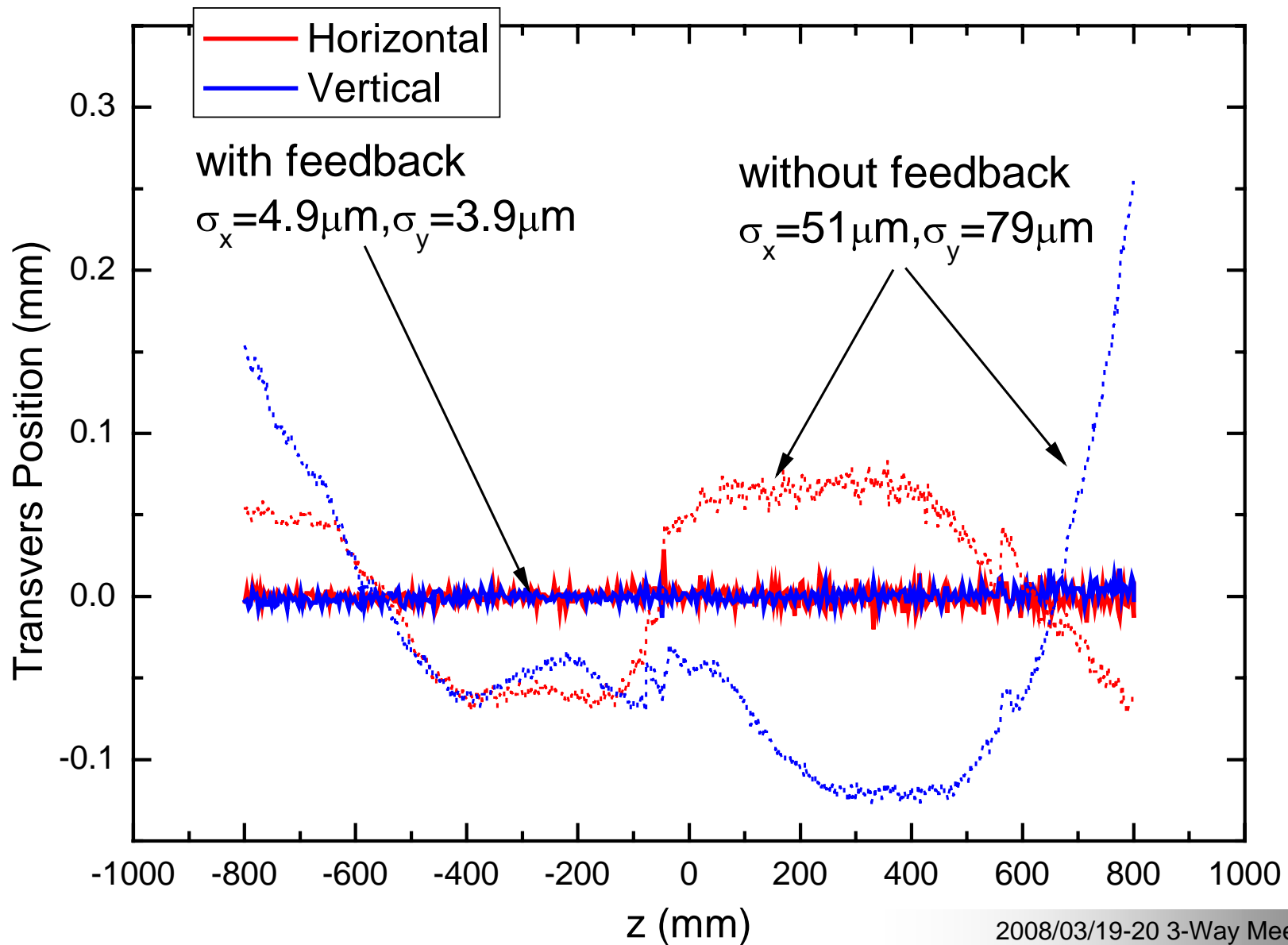

Measurement Reproducibility

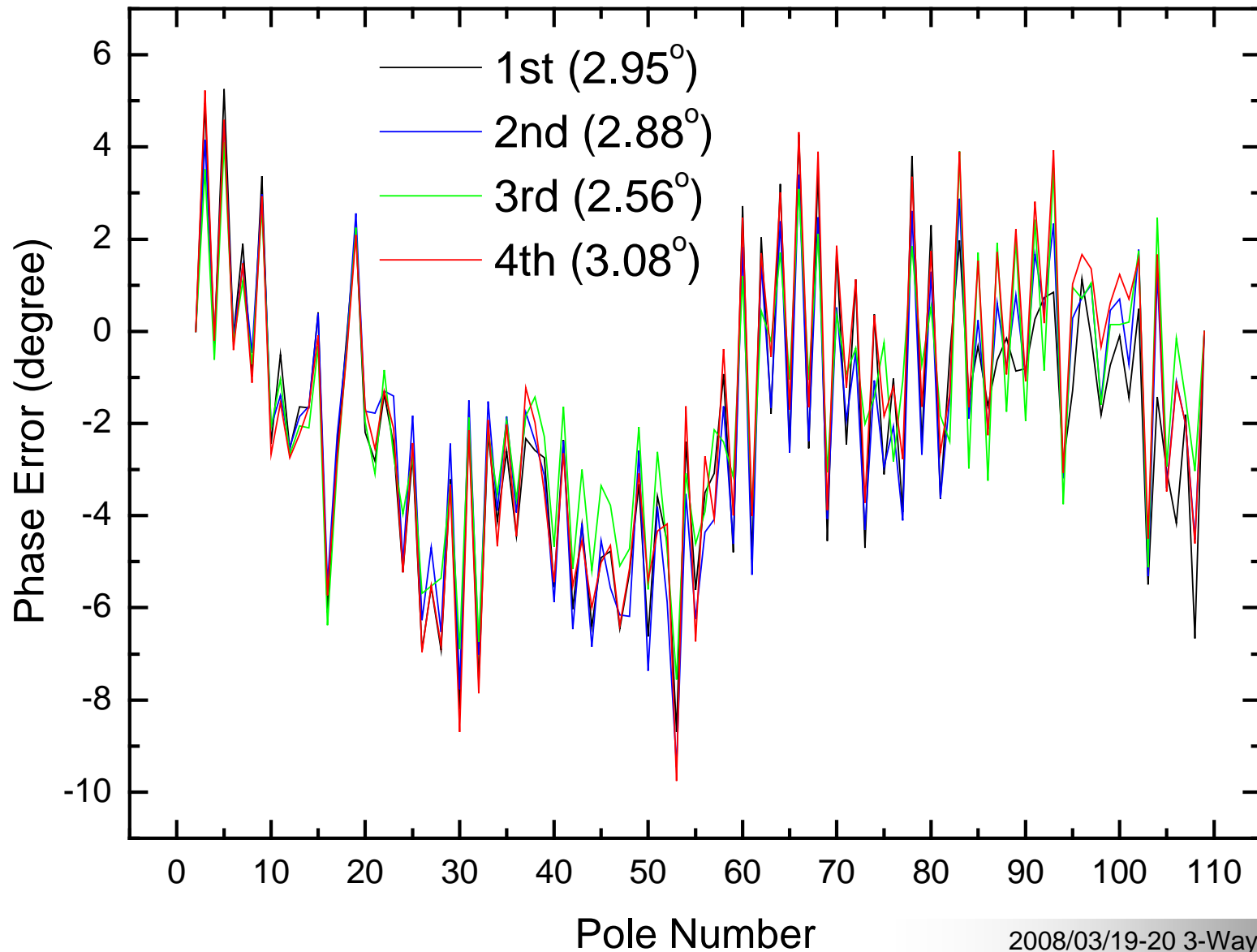

Measurement of U24

- U24 (PSI-SPring-8 Collaboration)
 - IVU with $\lambda_u=24\text{mm}$, $L=1.5\text{m}$
 - Constructed in 2000 and installed in PX BL @ SLS in 2001

**SPring-8 in-vacuum mini-gap undulator
installed in SLS ring
for Protein Crystallography Beamline (2001)**



Measurement of U24

- U24 (PSI-SPring-8 Collaboration)
 - IVU with $\lambda_u=24\text{mm}$, $L=1.5\text{m}$
 - Constructed in 2000 and installed in PX BL @SLS in 2001
 - Operated for 3.5 years
 - Returned to SPring-8 in 2006

Does the magnetic performance change during operation?

- ✓ Demagnetization
- ✓ Long-term Stability

Results of Measurement

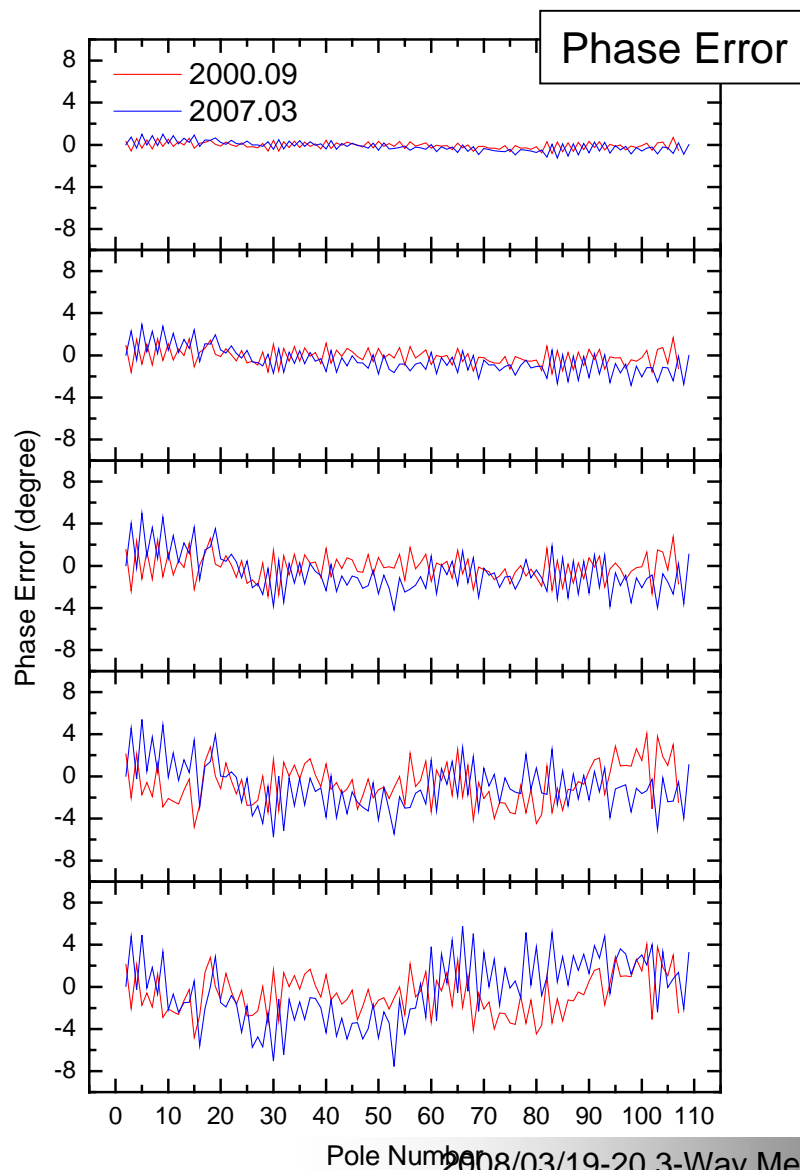
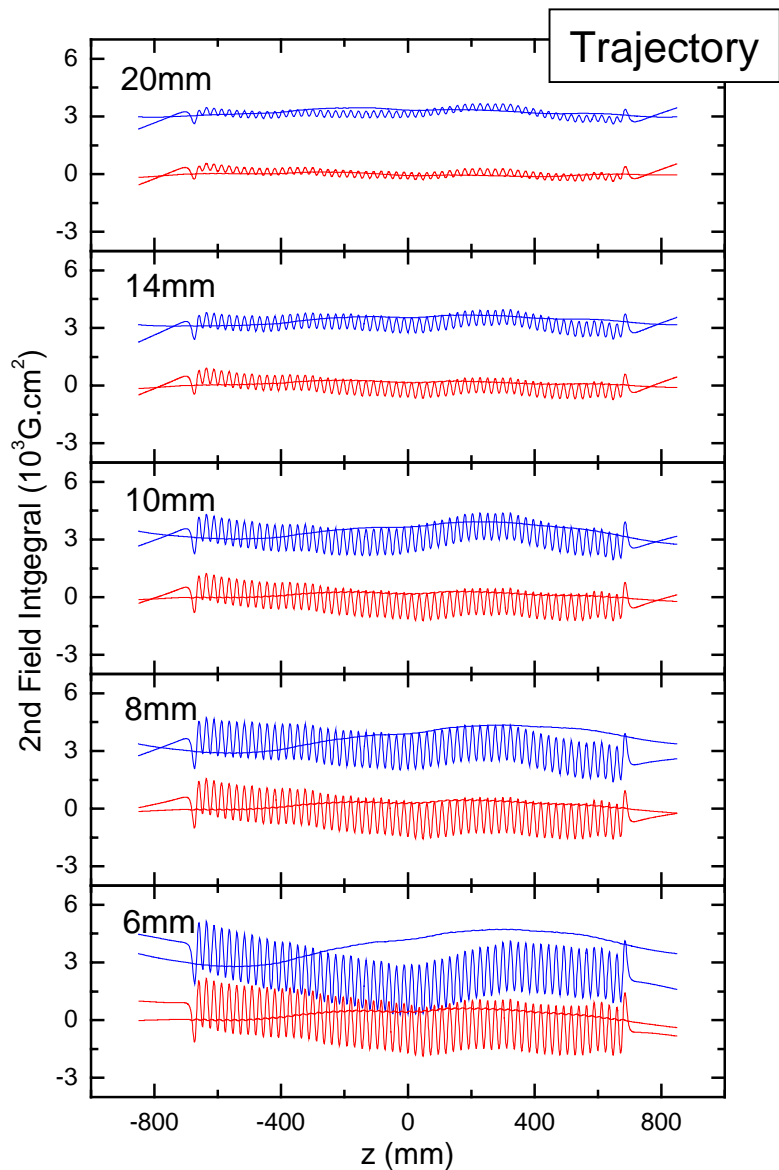

Summary

- In-situ field mapping of IVUs is critical toward realization of:
 - Shorter λ_u IVUs
 - XFEL & cryogenic undulators
- SAFALI: self-aligned field analyzer with laser instrumentation
- Outlook
 - Application to SPring-8 XFEL IVUs
 - Redesign of mechanical frame of IDs

Application to IVUs for SPring-8 XFEL

- XFEL Undulator

- In-Vacuum & Gap Variable ($g > 3.5\text{mm}$)
- 18-mm period hybrid configuration
- 18 segments, 5-m long

- Application of SAFALI

- Magnetic performance after assembly
- Effects due to temperature change
- Long-term stability

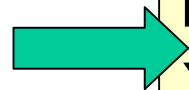

Measurement of the prototype
XFEL IVU is in progress.

Mechanical Frame Design

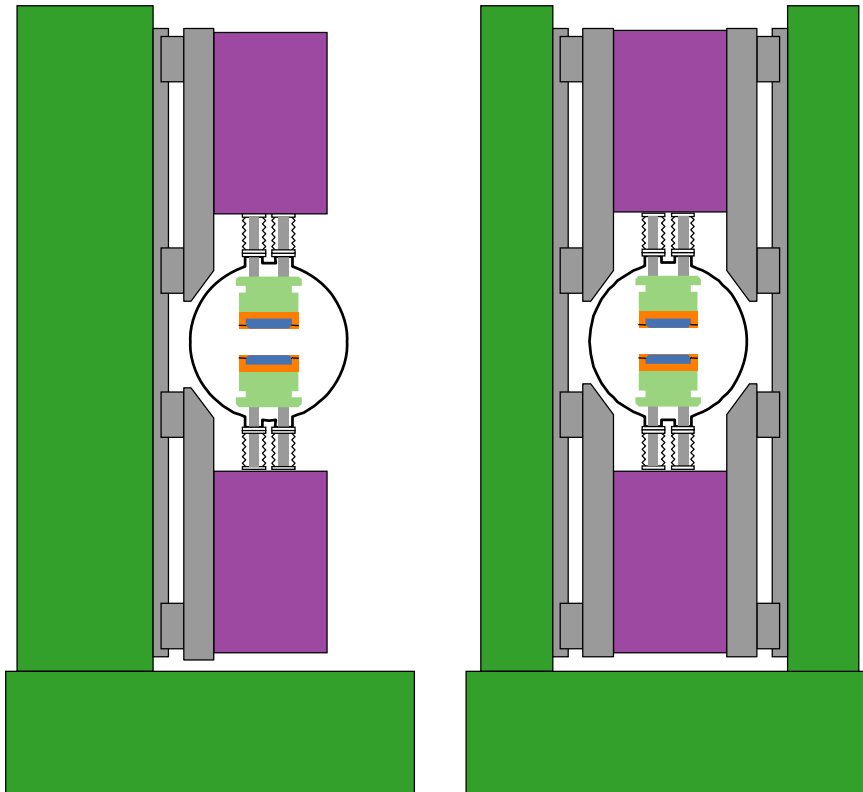

C-shape

H-shape

- H-shape Support
 - More rigid
 - Mechanical Stability
 - Design & Cost
 - No open access
 - △ Assembling
 - × Field measurement

↓
can be solved by means
of the SAFALI system.

Thank you for your attention!