

# Survey and Alignment of the KLOE Experiment at DAΦNE\*

A. Ceccarelli, S. Dell'Agello<sup>†</sup>, A. Di Virgilio, S. Moccia  
*Laboratori Nazionali di Frascati dell'INFN, Frascati (Rome), I-00044*  
for the KLOE Collaboration

## 1. INTRODUCTION

This review describes the survey and alignment work performed for the KLOE detector designed and built by the KLOE collaboration [1]. KLOE will operate at the DAΦNE  $\phi$ -factory  $e^+e^- \rightarrow \phi \rightarrow K_L K_S$  being commissioned at the Laboratori Nazionali di Frascati (LNF). The KLOE experiment, described below, is scheduled to start data taking in 1998, with the goal of studying a wide range of kaon physics topics, including a precision measurement of  $CP$  violation.

Survey and alignment have been of crucial importance for the construction of KLOE. Major projects, completed by October 1997, are:

1. assembly of the very large volume but extremely light-weight tracking drift chamber and stringing of the 52,140 wires; alignment of the stringing robotics and monitoring of the deformations of the chamber carbon-fiber structure [2][3];
2. assembly of the iron return yoke for the 0.6 T superconducting solenoid (the world's largest commercially-produced superconducting magnet), and alignment of the solenoid itself;
3. measurement of the position of the magnetic axis, with special care in the yoke pole regions, where DAFNE 500 MeV beams will be entering KLOE;
4. field map of the magnet volume where DC and calorimeter photomultipliers will be located.

Survey and alignment were carried out by means of a variety of hardware instrumentation, software and techniques. These include precision optical leveling, infra-red polar measurement (theodolite with electronic distancemeter total stations), distance measurement with invar wires pulled by the DISTINVAR (a tool developed by CERN), close range videogrammetry by an external firm, 3D contact measurements. We acknowledge extensive use of the powerful, block-adjustment software LGC ('`Logiciel General de Compensation'') developed by CERN for processing survey data, as well as the calibration of distance sensors in conjunction with our two total stations at the CERN geodetic interferometer base. A significant fraction of the alignment work involved almost real-time surveys, in which data were taken (with the CARNET program, another CERN product) and processed on site with a portable PC, without leaving the assembly hall before completion of the task. Fast feedback, portability and, in consideration of the tight schedule and of the limited manpower available, simplicity were the guiding principles in setting

---

\* KLOE, the KLONg Experiment, and DAFNE, the Double Annular  $\Phi$  Factory for Nice Experiments, are special projects of the Istituto Nazionale di Fisica Nucleare (INFN) at LNF, Italy

<sup>†</sup> Presented by S. Dell'Agello at the 5<sup>th</sup> International Workshop on Accelerator Alignment, Argonne, October 1997.

up a survey and alignment facility for KLOE. The Leica TC2002 total station and distance measurements were the core of our work.

This review is organized as follows: KLOE is described in section 2, survey tasks, methods instrumentation and software are discussed in section 3, while survey projects and results are presented in section 4 to 8 for each KLOE sub-system.

## 2. THE KLOE EXPERIMENT

KLOE is a typical general-purpose collider detector with  $4\pi$  coverage and cylindrical geometry. A relative low, 0.6 T, magnetic field over a very large volume, 4 m diameter and 4 m length, are a special requirement because of the low cm energy, 1.02 GeV and the long decay path of long lived kaons, 3.4 m in average. The detector consists of a very large tracking drift chamber (DC) and a hermetic electromagnetic calorimeter (EmC) subdivided in various parts. A pictorial view of the experiment is shown in Fig. 1.

The low energy scale set by the value of the  $\phi$  and  $K$  masses result in charged particle momenta  $0 < p < 510$  MeV/c. Photons from  $K$  decays have energies as low as 20 MeV.  $K_L$  decay vertices are uniformly distributed in radius and their decay products are isotropic distributed in azimuth, may spiral in the DC and enter the EmC at unusual angles: the projective geometry of typical collider events does not apply to KLOE. Furthermore, the large value of  $\int Bdl$  is a severe disturbance on the orbits of 500 MeV electrons. This imposes very tight constraints on the alignment of KLOE magnetic axis especially in view of the large luminosity of  $10^{33}$  cm<sup>-2</sup> sec<sup>-1</sup>, required by the experiment.

With its point resolution of  $\sim 200$   $\mu$ m in  $r$ -f and 4 mm in  $z$ , the DC is devoted to:

- detection and decay-length measurement of  $K_S \rightarrow \pi^+\pi^-$  decays in the 10 cm radius ball-shaped Be beam pipe ( $K_S$  mean decay path at DAΦNE is 6 mm);
- detection of  $CP$ -violating  $K_L \rightarrow \pi^+\pi^-$  uniformly spread in the DC volume ( $K_L$  mean decay path is 3.5 m);
- separation of  $K_L \rightarrow \pi^+\pi^-$  from background  $K_L \rightarrow p\pi n$  processes.

In order to reduce Coulomb multiple scattering of charged particles,  $K_L/K_S$  regeneration and photon conversions, the material in front of the calorimeter must be minimized. These requirements led to the choice of a cylindrical drift chamber with the following characteristics:

- diameter  $D=4$  m and length  $L=3.3$  m;
- immersion in a 0.6 T magnetic field;
- approximately uniform filling of the large tracking volume with 58 layers of all-stereo drift-cells, made of 119 (guard-sense-field) wire layers at constant radial displacement in the chamber midpoint ( $z=0$ );
- 90% He gas mixture;
- mechanical structure completely made of carbon-fiber/epoxy with just 9 mm thick walls, but capable of sustaining the 4 ton load of the 53K wires with an axial displacement  $\leq 0.5$  mm.

The average material in front of the calorimeter is  $< 0.1\%X_0$  and its effect in term of  $K_L$  regeneration is negligible. The DC has an inner cylindrical hole of 25 cm radius to allow the presence of six DAΦNE quadrupoles, the Be beam pipe (ball-shaped at the center of KLOE to provide a vacuum chamber for  $K_S$  decays) and the so-called “quadrupole” calorimeters (see below).

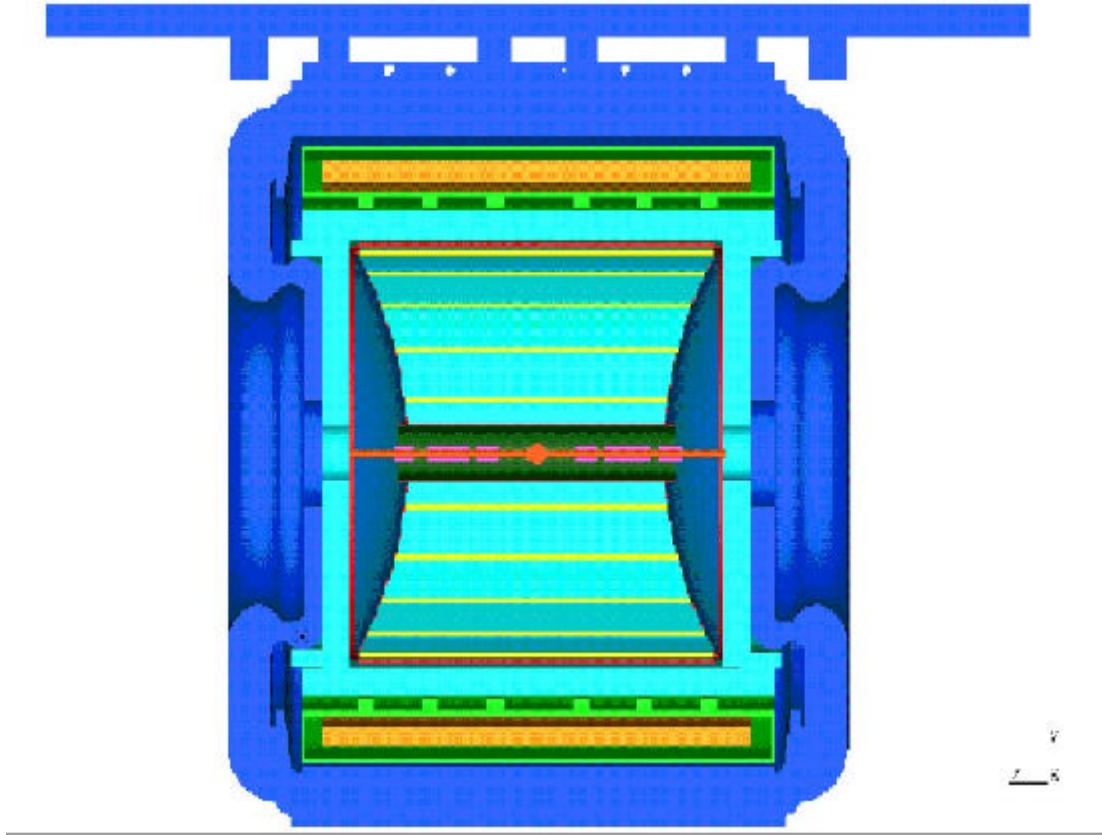

**Figure 1: cross section of KLOE, showing (from inside to outside): spherical Be beam pipe, quadrupoles, carbon fiber drift chamber with spherical end plates, barrel plus end cap electromagnetic calorimeters, cryostat with superconducting coil and the iron return yoke, which encloses everything. On top are 4 flat iron platforms with engines for opening and closing the 4 yoke end cap halves.**

The EmC must detect with very high efficiency extremely low energy photons from  $K_S/K_L \rightarrow \pi^0\pi^0$ , measure their energies with a resolution  $\delta E/E \sim 15\%$  at 100 MeV, provide the space coordinates of the photon conversion point in the EmCs with an accuracy of  $O(1)$  cm, and reject  $K_L \rightarrow \pi^0\pi^0\pi^0$  background. This is achieved with lead-scintillator sampling calorimeters using 0.5 mm grooved lead layers and 1 mm diameter scintillating fibers, yielding an excellent time resolution ( $55 \text{ ps}/\sqrt{E} \text{ (GeV)}$ ) and good energy resolution ( $4.7 \text{ } \%/ \sqrt{E} \text{ (GeV)}$ ). The chosen design provides a position resolution of  $0.9 \text{ cm}/\sqrt{E} \text{ (GeV)}$  on the coordinate along the fibers (by means of the time difference of the light measured at both ends). It also allows the construction of a truly hermetic calorimeter, with no outer shell to contain calorimeter modules except an Al

envelope of 0.1 mm thickness. The calorimeter is read out with a granularity of about  $4 \times 4 \text{ cm}^2$ . Therefore, the position resolution on the coordinates normal to the fibers is also  $O(1) \text{ cm}$ .

The EmC is divided into the following components.

- The central calorimeter, made out of 24 modules of trapezoidal cross section 4.3 m long, 23 cm thick approximating a cylindrical shell of 4 m inner diameter (fibers parallel to the detector axis) around the DC.
- Two *end-cap* calorimeters, each consisting of 32 modules 23 cm thick with different lengths positioned vertically along the chords of the circle inscribed in the barrel, which close the DC forward and backward (fibers normal to the axis).
- Two calorimeters surrounding the low  $b$  insertion quadrupoles located inside the DC (QCALS). QCALS are needed to increase the coverage for  $K_L \rightarrow \pi^0 \pi^0 \pi^0$  rejection by detecting photons which would be absorbed by the quadrupoles and remain undetected by the other EmCs. QCALS are sampling calorimeters made by lead and scintillator tiles with wavelength-shifter fiber readout.

For what concerns its physics goals KLOE is a precision, real general-purpose experiment. In fact, the choice of studying a pure quantum state with well-defined  $J^{PC}=1^{--}$  quantum numbers, the expected excellent performance of its detectors and the high design luminosity of the DAΦNE factory open up to KLOE a wide range of physics topics. These span from the precision measurement of K-decay branching fractions to the investigation of  $CP$  violation.

## 2.1 KLOE subsystems

From the point of view of large physics installations and related metrology aspects, KLOE is divided into four major subsystems (see Fig. 2): the DC, the EMCs, the iron yoke and the cryostat (4.4 m length, 6 m diameter) containing the superconducting solenoid. The iron yoke is divided into 34 large pieces with a weight of  $O(20)$  ton each. The main body of the yoke has (very roughly) a cylindrical symmetry and hosts the cryostat. This *barrel* yoke is also equipped with 4 wheels for movement along the rails and 4 engines to open and close the two *end-cap* parts of the yoke. Barrel EmCs are assembled inside the cryostat (whose robust steel shell supports their weight), end-cap EmCs are assembled directly on the yoke end-caps and the DC will rest on the barrel EmC inner surface.

Yet another subsystem, which is under construction and will not be described here, is the interaction region of DAΦNE and KLOE. A special structure will hold permanent quadrupoles and QCALS inside the DC by distributing forces and torques on DC end plates and barrel EmCs. The complexity of the interaction region is remarkable. Alignment and assembly of QCALS, quadrupoles, spherical Be beam pipe inside the DC in mid-1998 will be challenging tasks.

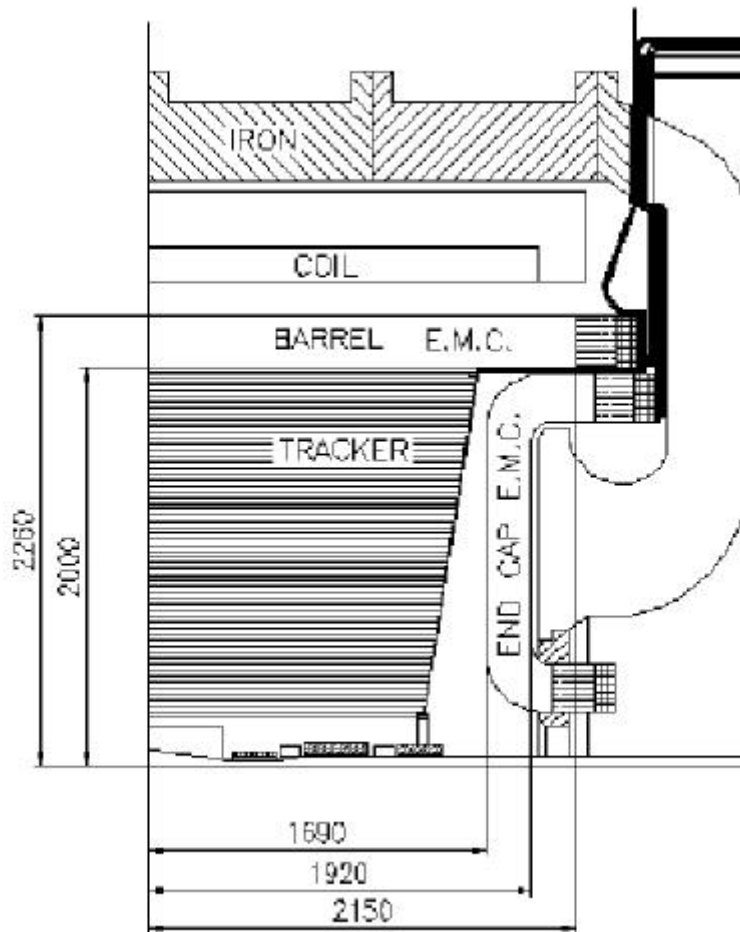

**Figure 2: one quarter cross sectional view of KLOE, showing approximate dimension and location of the four subsystems.**

The two detector elements (EmC and DC) were built at LNF. Two industrial firms (SALVER from Brindisi and ReFraschini from Legnano) provided the DC mechanical structure. Success of the work done at external firms was due to close and constant help and collaboration by KLOE members, which was a major manpower investment for several years. The iron yoke was built by INNSE (now part of the Mannesman group) in Milan. Oxford Instruments of England produced the solenoid and SKODA fabricated the cryostat outer shell, as a subcontractor. In this review we will report on the detector survey and alignment work at LNF and at external firms.

The assembly of the yoke and solenoid in the KLOE experimental hall (completed in December 1996) started with delivery of iron yoke parts at the end of March 1997. From a survey point of view the installation proceeded with the following steps:

- installation of experiment rails (November 1996);
- pre-survey of iron yoke at INNSE as part of the acceptance tests (February 1997);
- creation of a network of permanent survey points (March 1997);

- assembly of the highly-segmented barrel yoke (April-May 1997);
- alignment of the solenoid inside the iron yoke (May 1997);
- end-cap yoke alignment with respect to the solenoid (June 1997);
- survey of cryostat inner surface for barrel EmC installation (June 1997);
- survey after first KLOE translation along rails (July 1997);
- determination of KLOE's magnetic field axis (July-August 1997);
- survey and alignment of the CERN device for mapping KLOE's magnetic field in the DC tracking volume and in the region of EmC photomultipliers (September-October 1997).

### 3. SURVEY AND ALIGNMENT

#### 3.1 Tasks

The required survey accuracy and alignment tolerance, which provide the guidelines for the strategy and instrumentation to adopt for KLOE, vary with the subsystem.

The position-sensing elements of the drift chamber are sense wires located in the drift cells. For the KLOE DC we aim at a survey precision  $< 0.2\text{mm}$ . This is because survey positions have to be used as a starting point for a track fit algorithm, which has the ultimate goal of measuring wire positions with an error  $\leq 0.05\text{ mm}$ , significantly smaller than the DC point resolution ( $0.2\text{ mm}$ ). Sub-millimeter survey constants simplify and ensure the convergence of the fit, whose final precision is mainly limited by track statistics. On the contrary, for the relative alignment of the two DC end plates with respect to the axis connecting their centers, we can tolerate  $1\text{ mm}$  misalignments. In fact, rigid-body misalignments of this magnitude between the two end plates induce only variations of the drift-cell stereo angles  $< 0.2\%$ .

The position-sensing elements of the calorimeter are the  $4\times 4\text{ cm}^2$  bundles of fibers read out by light guides and photomultipliers. The coordinate of the photon impact normal to fibers is found by the energy-weighted average of the positions of the hit detector elements. The required EmC alignment tolerance and survey accuracy is  $O(1)\text{mm}$ , which makes the survey job less demanding than for the DC. For this detector the difficulty is related to:

- the large number of modules to install (24 in the barrel, 64 in the end-caps) with respect to a common axis,
- the goal of building a truly hermetic calorimeter where each module, not contained in any protective rigid case, is as close as possible to the adjacent modules.

The alignment of the iron yoke with respect to the solenoid is driven by the interaction of the experiment with DAΦNE beam optics. Accelerator physicists require an alignment tolerance  $\leq 1\text{mm}$  in the transverse plane on a  $6\text{m}$  length (related to KLOE's size), that is,  $< 0.2\text{mrad}$ . This tight constraint is related to the topology of the optics around KLOE and for a detailed explanation the reader is directed to the DAΦNE proposal.

## 3.2 Strategy

Prior to 1996, survey and alignment resources adequate to the installation of an experiment having the dimensions and complexity of a LEP detector (although with a smaller number of sub-elements) did not exist in the LNF Research Division. In view of the construction of KLOE, a team composed by one metrologist, one physicist and one engineer was charged with the responsibility of organizing an appropriate facility. At the time of the iron yoke survey, a second metrologist joined the team.

In addition to the tasks listed above, practical constraints we had to face were:

- (I) time limitations for the completion of the first task (namely the survey and alignment of the 1:1 DC prototype and of the wire-stringing robotics);
- (II) ease-of-use and effectiveness of the facility to setup (in part driven by I); we wanted our facility to be simple to operate, up to the limit of a single person using the theodolite, saving/processing the data with a portable computer and yielding the results *in field*, with the only help of a person placing targets, like employees of external contractors or random physicists (which happened quite often);
- (III) capability to perform surveys in very different conditions and locations, like at external firms (where technical support and possible planning turned out to be limited), in the DC clean room at LNF (which is a relatively stable environment) and in the KLOE hall (which is not as stable and controllable);
- (IV) choice of a block-adjustment software to process survey data (largely driven by I to III).

We chose to setup a single, basic survey unit, made by a precision total station (the Leica TC2002), associated targets, and a portable PC. We also chose to measure angles and distances for (almost) every surveyed point in order to decrease, when possible, the number of intersecting measurements from different theodolite positions. In this scheme, the complexity of survey tasks was to be solved by the adoption of powerful software (CERN LGC), capable of block-adjustment with only 1 measuring theodolite and by the redundancy of the measurements. Instead, there are commercially available programs, which work with at least two instruments, simultaneously pointing all targets. The TC2002 + PC + LGC seemed to us the fastest and simplest facility to setup, suited to KLOE needs and having the additional feature of portability.

## 3.3 Instrumentation and calibration

The TC2002 is a precision theodolite equipped with an infrared electronic distancemeter (EDM) based on the Wild DI2002. This total station has coaxial optics for the measurement of angles and distances from the same point, that is, the telescope is adjusted at the factory to make the infrared distance-measuring beam coincident with the telescope's line-of-sight. Thus, the TC2002 is capable of polar measurements for radii larger than its shortest focusing distance, which is about 1.6 m. Alternatively, the instrument can provide the same 3D information in a Cartesian reference frame with one axis coincident either with the plumb-line or its standing axis. Extensive use of the TC2002 for KLOE's survey and alignment has shown that is a precise, stable and versatile instrument, apt to our needs.

Our preferred targets are 3D spherical target pairs of various diameters, one for angle measurements and the other one containing a reflector for distance measurement. We used:

- two pairs of 26 mm diameter targets, mainly used for the DC end plates and robotics;
- two pairs of 40 mm diameter targets, mainly used for the yoke and the solenoid cryostat;
- two pairs of 88.9 mm diameter Taylor-Hobson spheres, which are mainly used on permanent network points or anyway in conjunction with CERN-standard reference-target sockets.

Whenever we can drill holes or use sharp edges on the object of our survey, we then build simple fixtures to place there 3D targets, which can be oriented at will towards the TC2002 without displacement of their centers. When manipulation and/or machining of objects to survey is not possible, we do extensive use of adhesive retro-reflective tape targets, as in the case of EmCs and, to a lesser extent, for the cryostat and the yoke. Tape targets with superimposed geometrical design can greatly ease manual observation (allowing both distance and angles to be measured), and are best used when well-defined points are required, but their actual position is not of major importance, for example as fixed reference points or to define a free-form surface.

Although the TC2002 is built with an intrinsic angular accuracy of 0.00015 gon ( $\sim 2\mu\text{rad}$ ), in field we normally achieve an accuracy  $\leq 0.0010$  gon, as indicated by LGC. Since on average we do measurements in a 2-10 m range (and never exceed 20 m) the quoted angular error amounts to 0.1-0.2 mm position error. The distance along the line-of-sight is measured with a similar uncertainty, as shown by the calibration of TC2002 plus 3D reflectors at the CERN interferometer geodetic base and confirmed by LGC. Fig. 3 shows the deviation of the distance measured by the TC2002 with our reference Taylor-Hobson reflector (used only for calibrations) with respect to the interferometer. The slope of the data points (about  $-25$  ppm) is due to the *atmospheric correction* (temperature, pressure and humidity, in order of decreasing importance). This correction was on purpose not applied to the data to show its magnitude. The intercept of the data at DTC2002 $\rightarrow$ 0.0 m is the target *constant* with this instrument. Fig. 4 shows the comparison of the data of Fig. 3 (diamonds labeled “*matin*”) with the same calibration in the range 1.6-35 m and with coarser steps (triangles labeled “*apres midi*”) repeated at a different time: a systematic shift of 0.1 mm is apparent. The accuracy of distance measurements with Leica retro-reflective tape is about a factor two worse than for 3D reflectors, as shown by the calibration of tape targets with an interferometer in Fig. 5 (these data are taken from a certificate that we bought from Leica). This calibration is performed with a tape orientation normal to the line-of-sight; when observing at a different angle (in any case not smaller than  $60^\circ$ ) it is necessary to average the distances taken in the two telescope positions in order to get the accuracy of Fig. 5.

The calibrations of 3D targets occurred in October 1996. Since then we periodically check the cross calibration with respect the reference prism by placing all targets in a standard CERN socket (using appropriate extensions for diameters  $\neq 88.9$  mm) and measuring the distance with the TC2002 forcefully centered in another socket. The absolute calibration is then obtained by measuring the distance between the CERN socket centers with the Invar / Distinvar technique, with an accuracy of about 0.05 mm. After intensive use of the 26 mm targets for the DC, we measured in this way a drift of their calibration constant of 0.4 mm and 0.6 mm. Additional



checks can be performed by comparing coordinates of CERN sockets measured by the TC2002, with those given by our CMM in its fiducial volume.

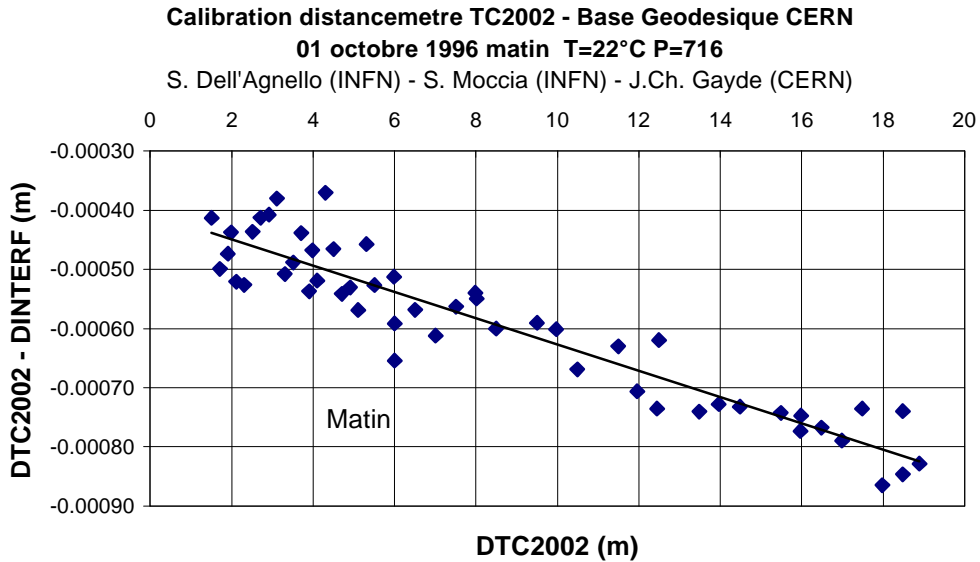

**Figure 3: calibration of KLOE's TC2002 with 3D reflectors with CERN's interferometer.**

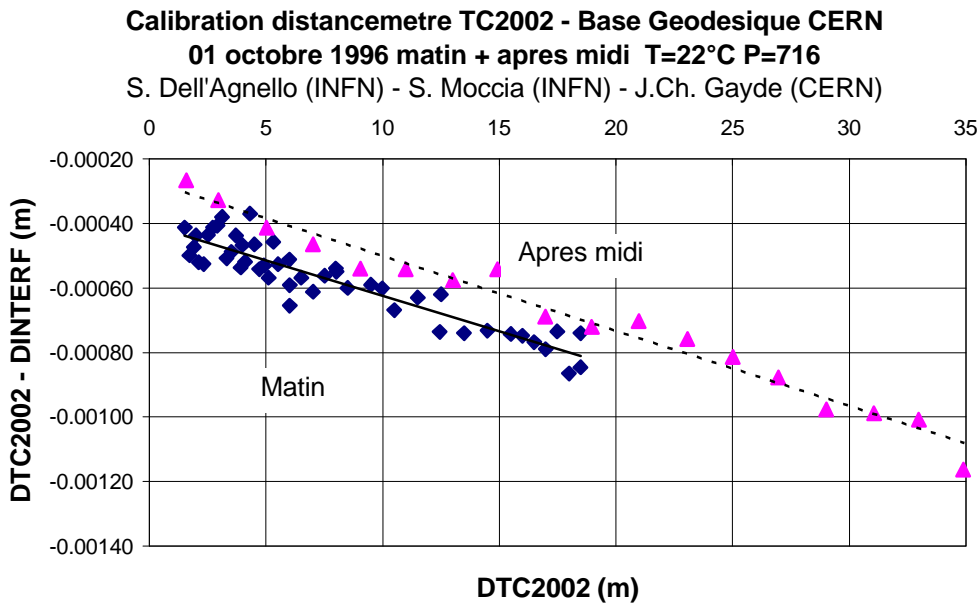

**Figure 4: comparison of different calibrations of KLOE's TC2002 with 3D targets.**

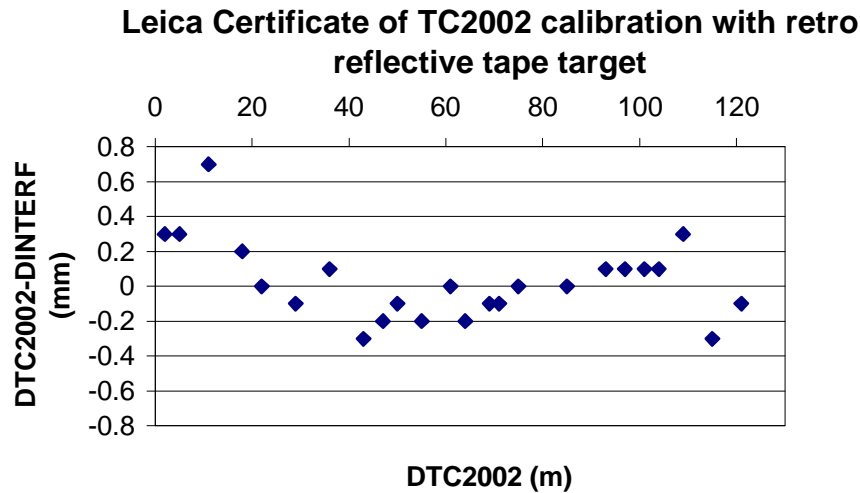

**Figure 5: calibration of KLOE’s TC2002 with retro-reflective targets bought from Leica.**

The TC2002 total station was complemented by other instruments.

- For leveling with accuracy better than 0.05 mm we utilized the Leica NA2 automatic level and a 0.92 m invar staff, which we used extensively for the DC (see below). This level equipped with the Leica GPM3 parallel plate micrometer is capable of 0.02 mm reading.
- A ~1 mm accuracy total station, the Nikon DTM-A20LG, which was used at the beginning of our work for the alignment of the DC 1:1 prototype.
- The Nikon AS automatic 0.1 mm reading level (with its parallel plate micrometer).
- Other electronic and manual theodolites, all of quality nowhere near that of the TC2002.
- When we needed 3D surveys of accuracy better than 0.05 mm to check the DC end plate drilling and measure DC reference holes we decided to rent the service of a private company, after getting acquainted with the technique.
- For 0.01 mm accuracy the LNF CMM was used to survey objects fitting its 1.2×1.0×0.6 m<sup>3</sup> fiducial volume, and to check target supports/extensions which allow viewing targets (especially 3D targets) in positions visible from fixed theodolite points. Many of these essential accessory parts were made by our machine workshop.
- For special but important applications, like surveying the deformations of the DC end plates under various types of loads, lengthy contact measurements by means of dial gauge micrometers were needed [3]. In fact, for their large diameter (4m), they did not fit the volume of common workshop machines or CMMs and this turned out to be the most practical way to measure deviations from nominal shape.

### 3.4 Software

Use of a block-adjustment software package to process survey data is a must in complex positioning metrology projects, like constructions of general-purpose physics experiments. Upon official request to the CERN survey group by the KLOE and LNF management, we were granted the use of a copy of the executable of (the Windows 3.1 version of) LGC, a versatile package developed over the years at CERN. Some important features of LGC are:

- error compensation and coordinate adjustment at global level;
- gross-error detection for single measurements (which allows the user to throw away or re-survey suspect points);
- statistical information to assess the overall reliability of the survey and its real accuracy (which is usually worse than the nominal instrument accuracy);
- simulation of survey results for the chosen input geometrical configuration of points to measure, type, number and accuracy of measurements;
- utilities for viewing output coordinates in different reference frames (CHABA) and fit the data to basic geometric figures, like planes, circles and straight lines (FIGMOY).

Our typical working sequence is to read out and save TC2002 measurements on the portable PC via the serial port with the CARNET program, and then LGC-process the data on the PC itself before leaving the KLOE assembly hall. However, when block-adjustment is not of major importance and fast feedback is needed, we do not use the PC and exploit, instead, the built-in calculation capabilities of the TC2002 to read directly on its displays the information of interest. This may apply to:

- first positioning of an object, which has to be refined at a later stage;
- direct survey of its dimensions (by taking distances of point pairs) and its inclination with respect to the vertical;
- establishing an approximate Cartesian network of points for later use.

This can be done by exploiting directly the TC2002 local coordinate system or by means of the so-called *coordinate-geometry* (COGO) functions. Some COGO functions allow a simple resection of the instrument with respect to a maximum of 6 reference points and further calculation of the position of other points in the reference frame of the resection points. In any case this use of the TC2002 requires manual input of reflector constants and of the atmospheric correction, while when working with the PC only target labels need to be entered as all constants and corrections are added by CARNET. This *free station* feature (used for about 20 % of the jobs) of the TC2002 proved very practical in the large physics installation of some of the 20 ton parts of the KLOE iron yoke (for a total of 34 pieces). Most often, however, results obtained with this method are checked with LGC.

## 4. DRIFT CHAMBER

### 4.1 Mechanics

The C-fiber mechanical structure consists of 2 spherical end plates (EPs), which close it longitudinally, 12 struts holding the EPs in place and 12 outer panels plus an inner tube of diameter  $d=0.5$  m, which seal the gas volume. The inner tube is not a structural element, as it carries no load and it is left floating at wire-stringing time. The outer panels also carry no load, as they are mounted and glued to struts and to EPs after stringing. However, they provide additional torsion and bending rigidity, which helps for a safe handling of the DC during transportation to the KLOE hall. An open view of the DC is shown in Fig. 6.

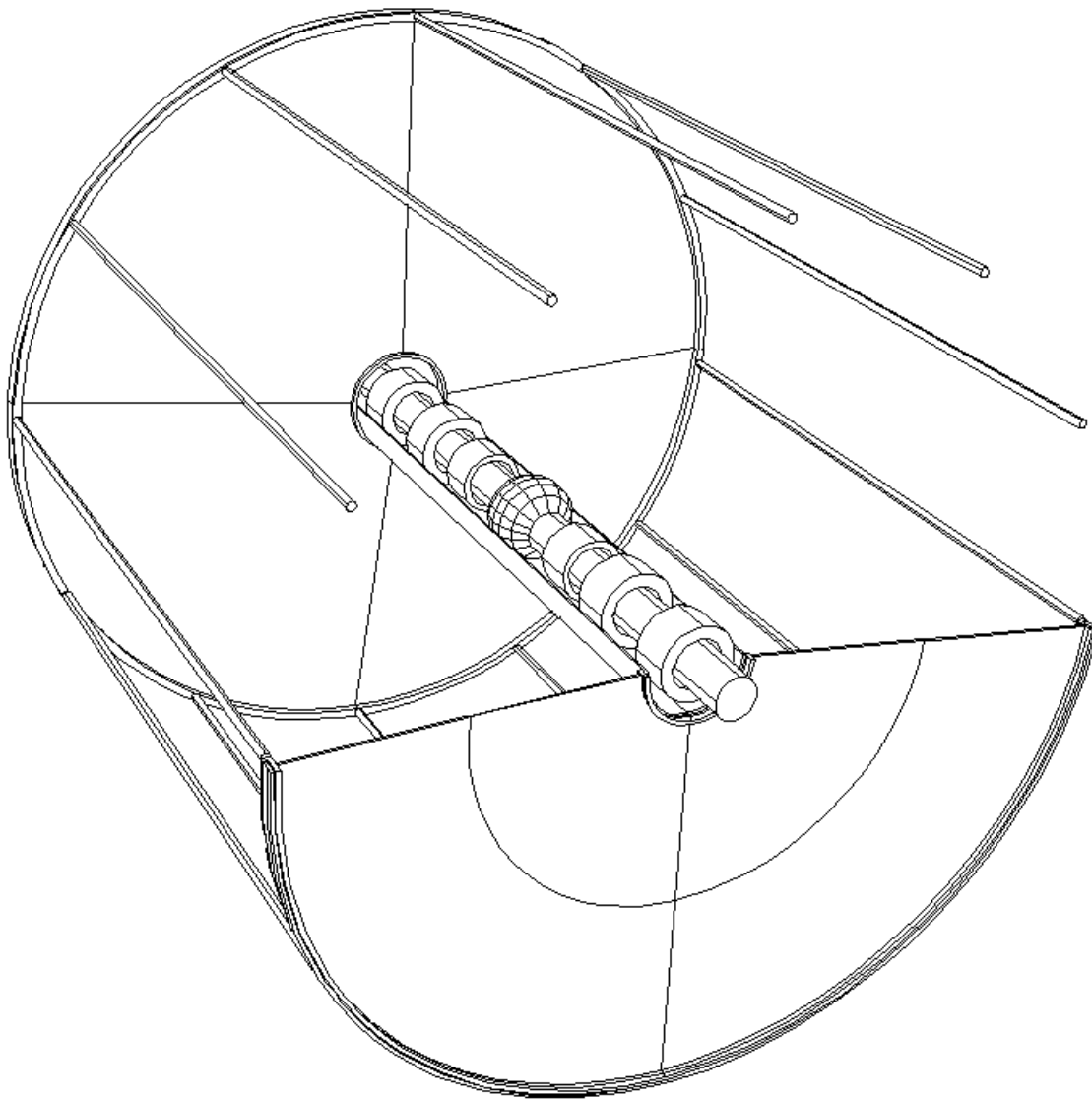

**Figure 6: open view of the KLOE carbon-fiber structure drift chamber showing spherical end plates, struts, quadrupoles and spherical Be beam pipe.**

To meet the requirements on its thickness and axial displacement each EP is made of:

- a C-fiber spherical shell of  $R \sim 10$  m curvature radius and 9 mm thickness;
- an outer flange, OF, which closes its outer diameter (note that a similar inner flange, IF, closes its inner  $d=0.5$  m diameter);
- a separate concentric C-fiber ring of slightly larger radius, located around the OF and connected to it with 48 titanium screws with built-in strain gauges.

EPs thus built show membrane behavior under our typical wire loads, which implies small axial displacement compared to flat plates of the same thickness. When the wire load causes a significant EP displacement, screws are tightened, this *tensioning ring* (TR) contracts and, by elastic reaction, applies to the OF, by means of the screws, an outward radial pull (proportional to the TR deformation). The choice of optimal frequency (every how many strung wires) and applied magnitude (read out from the 48+48 strain gauges) of EP tensioning, relies on predictions of the IDEAS engineering program, extensively checked with direct tests carried out on EPs before the DC assembly. These extensive mechanical tests performed on all DC components before their assembly (surveys of their shape and size, of accuracy of wire-hole drilling, measurements of their displacement or deformation under load), as well as the TR working principle are described in detail in ref. [3].

#### 4.2 EP reference targets

Before massive drilling of wire holes, special reference marks (RMs) were machined on EPs and their position measured by means of a one-day videogrammetry (VG) survey. These DC reference targets (the RMs) are precisely machined holes, whose x-y position is known within a resolution  $\sigma_{VG}=30\mu\text{m}$ . RMs are then surveyed with the TC2002 or NA2 using our 26 mm diameter 3D target pairs mounted into them by means of suited supports. RMs are divided into 2 classes:

- 12 holes of 6 mm diameter located on EP flanges for the DC survey and alignment, six of which define the x axis, while the other six define the y axis. For each axis, two are located on the IF (IRMs) and four are located on the OF. Among these four, two are axial holes (ORMs) like the IRMs, while the remaining two are radial holes (RRMs);
- 54 holes of 5 mm diameter uniformly distributed on EP shells for the survey of EP deformations (see below). On each EP there is roughly one "plate" reference mark (PRM) every  $50 \times 50 \text{ cm}^2$ .

The VG survey was very important also to check accuracy of the drilling machine in its actual working conditions, as RMs were drilled in the same configuration of the wire holes. In fact, on the basis of VG results, adjustments of the drilling procedure were introduced to achieve an overall accuracy of drill hole positions  $\sigma_{DR}=100\mu\text{m}$  in both x and y coordinates of the EP plane. The VG survey output was a least-squares fit of the nominal positions of the four IRMs and four ORMs, which establishes the local Cartesian reference frame. The coordinates of RRs and PRMs are then given with respect to this frame. This follows the

operational drilling procedure. RRM's have been excluded from the fit, because for one of the EPs they were drilled at a later stage, after VG was performed.

### 4.3 Automated wire stringing

A description of the wire stringing facility and procedure can be found in ref. [4]. Here we only remind that all operations are performed in a clean room by three robots remotely controlled by one Power Macintosh computer running Labview. Fig. 7 shows a top view of:

- the platform supporting the robots and the DC;
- wire-carrying robot P and robots A,B equipped with crimping/tensioning tools;
- EPA and EPB mounted via IFs on a support Fe tube (EPB is on the engine side);
- the DC  $\phi$ -rotation engine located at the right end of the Fe tube;
- KLOE Cartesian x and z axes.

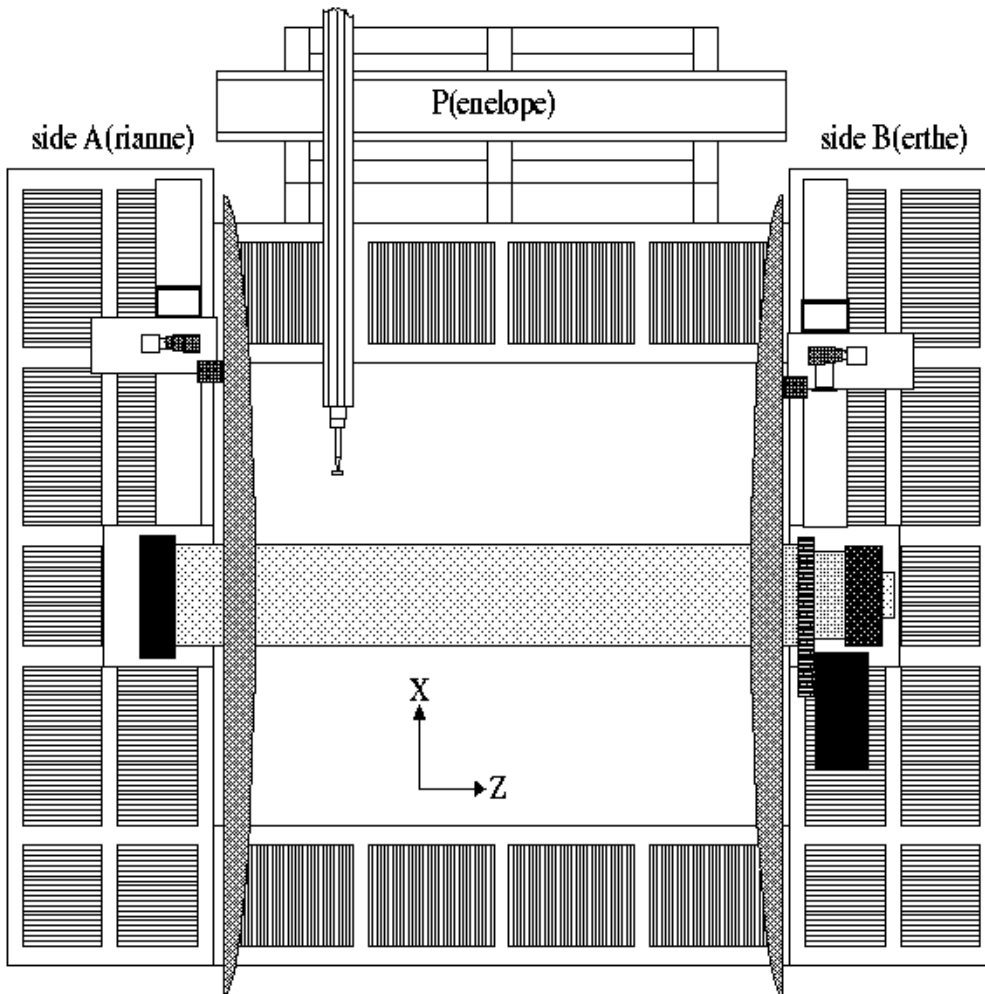

**Figure 7: top view of the supporting rig and the three robots for the automated wire stringing of the KLOE drift chamber.**

The Fe tube is machined to have a precise coupling with IFs (by means of Al flanges and prismatic guides), such that its axis is coincident with the IF axis, thus defining the KLOE z direction (with origin on this axis, at half way between EPs). The y-axis is taken along the opposite of the gravity acceleration. IFs are free to move longitudinally when the wire load causes displacement of the shells, with the relative IF-Fe tube sliding allowed by the prismatic guides. The C-fiber inner-tube, not shown in the figure is outside the lower-diameter Fe tube and is pre-glued to one IF and free to slide inside the other one. The C-fiber tube will then be sealed onto the IFs at the end of stringing. Also not shown in the figure are the 12 struts, which keep apart the EPs.

The clean room, operational since March 1996, works at 22°C and is class 1000 in the DC area and class 10000 elsewhere. An electronic system measures the wire mechanical tension by applying an appropriate voltage to wires and exploiting their capacitive coupling with neighbor wires.

#### 4.4 Survey and alignment results

Survey of the DC assembled on this support structure involved the measurement of the following quantities with the NA2, the TC2002 and LGC:

- deviations from planarity of the ORMs of each OF,  $\Lambda_{EP}$ ;
- deviations from parallelism between each OF average plane and the respective IF average plane,  $\lambda_{EP}$ ;
- the relative  $\phi$  rotation of the two EPs around the z axis,  $\phi_{EP}$ ;
- relative rotations of the two EPs around the x and y axes,  $\theta_{XEP}$  and  $\theta_{YEP}$ ;
- relative shift of the two EPs in the x-y plane,  $S_{X,Y}$ ;
- relative z distance of middle points of IFs (this quantity is much less relevant than the others and needs only to be surveyed when we stick the DC into the calorimeter).

We find  $\Lambda_{EPA} = 0.4 \text{ mm} \pm 0.1 \text{ mm}$  and  $\Lambda_{EPB} = 0.1 \text{ mm} \pm 0.1 \text{ mm}$  and  $\lambda_{EP} \sim \Lambda_{EP}$ . Moreover, OF and IF of each EP are concentric in x-y within our position resolution.

Alignment of the EPs around the z axis is achieved by finely rotating EPA with respect to EPB by means of a removable metal tie-rod attached to its OF. EPA is loosened on the tube and on the struts, while EPB is held fixed by the  $\phi$  engine, which works with a feedback encoder. Then, the longitudinal axis is set horizontal by acting on the support tube. This iterative mechanical action was driven by the following optical measurements: the  $\phi$  alignment is done by setting the EP x axis horizontal, separately for each EP, using the NA2 to level targets located on the two x-axis ORMs. Repeating the procedure with the y axis and averaging statistically compensates having to measure two EPs. IRMs are also measured as a check but they do not provide a significant improvement of the measurement, since their distance is reduced by a factor 7.5 compared to ORMs. Taking into account instrumental and target accuracy,  $\sigma(\phi_{EP})=0.015 \text{ mrad}$ . We measure  $\phi_{EP}=0.36 \text{ mrad}$ , which amounts to 0.7 mm displacement in the x-y plane at the ORM radius.

By using RRM we find  $\theta_{XEP} = 0.15 \text{ mrad} \pm 0.15 \text{ mrad}$ ,  $\theta_{YEP} = 0.31 \text{ mrad} \pm 0.15 \text{ mrad}$  and  $S_X = -1.8 \text{ mm} \pm 0.2 \text{ mm}$ ,  $S_Y = +1.1 \text{ mm} \pm 0.2 \text{ mm}$ . Note that relative EP rotations and shifts are geometrically and mechanically related. They are misalignments of negligible effect on the robots, because robots were aligned with respect to each EP separately. Their effect on the value of the wire stereo angles is discussed below.

#### 4.5 Stereo angles

The nominal stereo angle,  $\varepsilon$ , varies from  $\pm 63 \text{ mrad}$  for innermost layers (radius of 275 mm) to  $\pm 148 \text{ mrad}$  for outermost layers (radius 1937 mm). Note that the contribution of  $\sigma_{DR}$  to the error on  $\varepsilon$  is  $\sigma_\varepsilon(DR) \sim 0.050 \text{ mrad}$ . In the following we consider, separately, the implications of non-zero values of the largest angular rotation,  $\phi_{EP}$ , and of the combined shift  $S_{XY} = \sqrt{S_X^2 + S_Y^2}$ .

The measured value of  $\phi_{EP}$  produces a systematic variation of  $\varepsilon$ , which is *uniform* across cells of a layer, of about 0.22 mrad for the outermost layer (0.15 % of its value) and of about 0.035 mrad for the innermost layer (0.06 % of its value). The contribution of the survey accuracy on  $\varepsilon$  is  $\sigma_\varepsilon(SR) < 0.010 \text{ mrad}$  for all layers.

A parallel, rigid-body EP shift  $S_{XY} = 2 \text{ mm}$  has a different effect depending on how the DC axis (defined as the line connecting EP centers) is installed with respect to the KLOE magnetic axis (which needs to be parallel to the bisectrix of DAΦNE beams in the center of KLOE). If:

- the DC is installed with one EP plane normal to the magnetic axis,
- DC stereo angles are computed with respect to the magnetic axis, i.e. considering EP B is misaligned,

then the 2 mm shift would produce a variation of  $\varepsilon$  *non-uniform* throughout cells of a same layer (some stereo angles increase and some other diminish). For example, for innermost layers the variation goes from  $-1.1 \%$  to  $+1.1 \%$  ( $\pm 0.7 \text{ mrad}$ ), which amounts to a systematic 2.2 % relative non-uniformity of  $\varepsilon$  within a layer, which would add to the complication of cell-to-cell calibration of the DC. Instead, if the DC is installed with its axis as coincident as possible with the magnetic axis, none of the EPs will be normal to the magnetic axis, but they will be tilted by 2.4 mm (and still parallel) over the diameter of the outermost layer. The systematic variation of  $\varepsilon$  (with respect to the magnetic and DC axis) will be again non-uniform within a layer, but much smaller in magnitude ( $< 0.2\%$  systematic variation). Note that the contribution of the survey accuracy on  $\varepsilon$  is  $\sigma_\varepsilon(SR) < 0.070 \text{ mrad}$  for all layers.

#### 4.6 Wire stringing robotics

The second part of the job was the survey of robot positions and the alignment of their motion rails with the KLOE Cartesian reference frame. Several iterations were needed to mechanically adjust the rails of the wire crimping robots A and B to make them straight and orthogonal. It was necessary to align the wire-carrying robot P with respect to the each EP



separately, since its 3m long rails showed deviation from straight-line motion at the order of 2 mm. In addition, the encoder of its y motion had to be calibrated (it showed before 2 mm errors) and the sizeable y-bending of its x arm when reaching inside the DC (10-20 mm depending on z) was carefully surveyed. As a result of the work, the robot hardware and software were improved.

The robot survey was done with the NA2, the invar staff, the Nikon total station and 3D target pairs of 26 mm diameter mounted on the robots (in the place of the crimping jaws or of the wire needle support) by means of ad-hoc precisely machined fixtures. This instrumentation was adequate for the required alignment tolerances:

- 0.5 mm for robot P, whose main task is centering the 3 mm diameter holes with a 1 mm diameter needle;
- 0.2 mm in y (the automatic jaws close vertically) and 0.5-1.0 mm in x and z (the jaws are flat in x and the metal pin can be crimped equally well on O(1) mm z position) for robot A/B.

Survey and alignment in y was done using the level. Triangulation was performed with the TC2002 total station and 3D targets provided x and z information.

#### **4.7 Measurement and Control of EP deformation**

A special task was the measurement of the z-displacement profile of each EP shell in connection with the tensioning of the outer ring, which occurs roughly every one month of wire stringing (about every 7000 strung wires). The measurement takes full advantage of the TC2002 and LGC. It consists of the survey of EP deformations and of the relative distance of RRM to check the null change of axial length of the struts. EP deformations are given in terms of z-coordinate variations of IRMs and PRMs with respect to the ORM average plane. The 26 mm diameter 3D targets were used for this work. These surveys were important, at the very beginning of the wire stringing, to confirm that leaving IFs floating was the optimal choice (vs. the option of constraining them in a fixed position) to avoid freezing the EPs in a non-equilibrium position. In fact the survey showed that keeping the inner flanges fixed induced unwanted and dangerous deformations of the DC structure, making it difficult to control the wire mechanical tension and sagittae. We corrected and smoothed this situation by means of the tensioning rings using the TC2002 to check the effectiveness of the tensioning process.

The tensioning rings are very effective in adjusting EP z-displacement due to the load of the strung wires in such a way as to control wire sagittae. Fig. 8 shows that sagittae are of the order of 0.25 mm, after about 45000 strung wires (7 tensionings), which is the optimal value for the safe electrostatic operation of our drift cells. In addition, the uniformity of the sagitta across all layers (except layers 1-11) makes unnecessary lengthy and difficult cell-to-cell calibrations. Note that after the attempt to string with IFs held fixed (described above) layers 1-11 ended up with sagittae of about 0.7-0.8 mm. To reduce this to a lower and safer value, we progressively increased the tensioning magnitude. For example, the applied pull on EPs at the 7<sup>th</sup> (most recent) tensioning was such that the z displacement recovery (difference after/before

tensioning) was on average 0.6 mm/EP, as shown by Fig. 9 and produced wire sagittae of Fig. 8. Progressive EP tensioning is an essential ingredient for the successful construction of the KLOE drift chamber.

Note that results in Fig. 9 are obtained from the measurement of the wire mechanical tensions and are, thus, independent of survey. However, TC2002 measurements and wire mechanical tension results are in good agreement, providing a positive check of the robustness of our redundant measurement system.

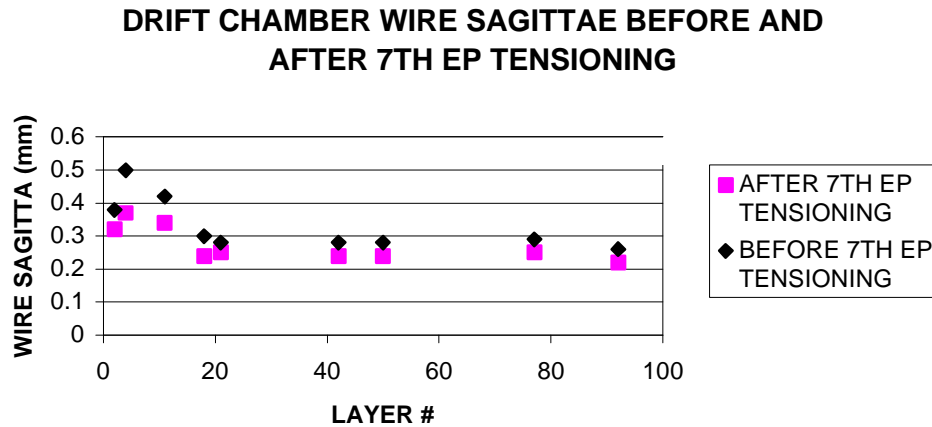

**Figure 8: KLOE drift chamber wire sagittae calculated from the measurement of wire mechanical tension, obtained independently of survey.**

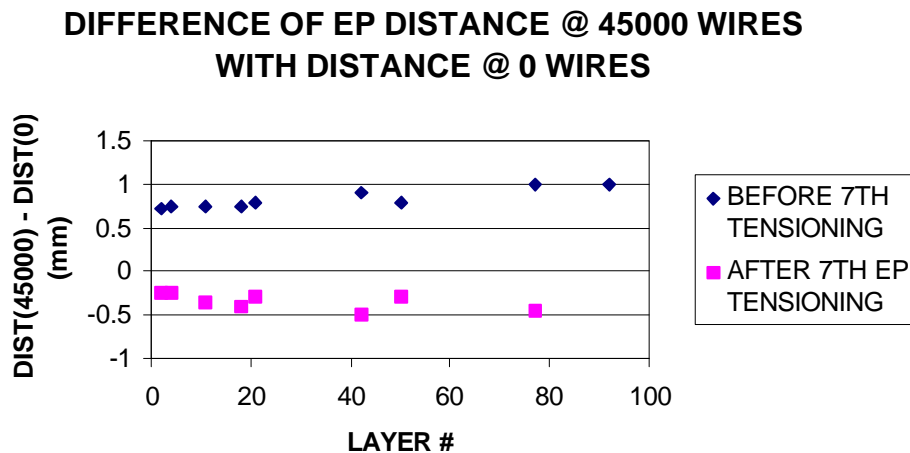

**Figure 9: adjustment of the distance of the KLOE drift chamber end plates by end plate tensioning in order to control wire sagittae. Results are obtained independently from survey and are in agreement with TC2002 survey results.**

## 5. CALORIMETERS

The size and shape construction accuracy of each standalone calorimeter module is  $O(1)$  mm level and they have been surveyed in detail with an accuracy better than 1 mm by means of contact measurements and the Nikon AS level. The layout of calorimeters is shown in Fig. 10.

### 5.1 Barrel

On each of the two ends of each barrel module, two cross hairs have been engraved on anodized aluminum plates. The position of light guides which view the  $4\text{ cm} \times 4\text{ cm}$  sensing elements (and feed their light to photomultipliers) has been surveyed with respect to the cross hairs. This has been done using a precisely machined plexiglass mask with a superimposed design showing the nominal positions of light guide centers with respect to the cross hairs. Survey results are part of the EmC database. Retro-reflective tape targets have then been positioned with their design coincident with the cross hairs to be measured by the TC2002. We estimate an overall survey accuracy of the relative position of light guides with respect to targets better than 1 mm.

At the time of their installation into the cryostat (November-December 1997), barrel modules will be mounted trying to make their axis coincident with the measured magnetic axis (see below) and to reach a hermetic configuration, by minimizing dead zones at lateral junctions of modules. Tape targets will be surveyed with accuracy better than 0.5 mm by the TC2002. We aim at an alignment tolerance of a few mm, but the actual alignment configuration will be driven by mechanical constraints, like the regularity of the cryostat inner surface. This was surveyed in June 1997 to know how to shim the EmC modules.

### 5.2 End cap

End cap modules have been mounted before barrel modules in October 1997. Setting the reference targets for the end caps was similar to the process followed for the barrel. However, in this case the position of the light guides is known with respect to retro-reflective tapes glued directly on the 0.1mm Al skin of the front face of the calorimeters. This was done by means of contact measurements. End caps modules are grouped into 4 halves (two for each side), and they will be assembled onto corresponding halves of the iron yoke end caps by means of special iron plates, with their plane normal to the magnetic axis and their geometrical center lying on that axis. The mounting plates are mechanically designed to ensure the correct alignment of the detector (with a tolerance similar to that of the barrel) and have the suited magnetic properties to be part of the iron yoke poles. In fact, during the magnetic measurements, prototype plates with the same properties have been used to precisely simulate the final configuration.

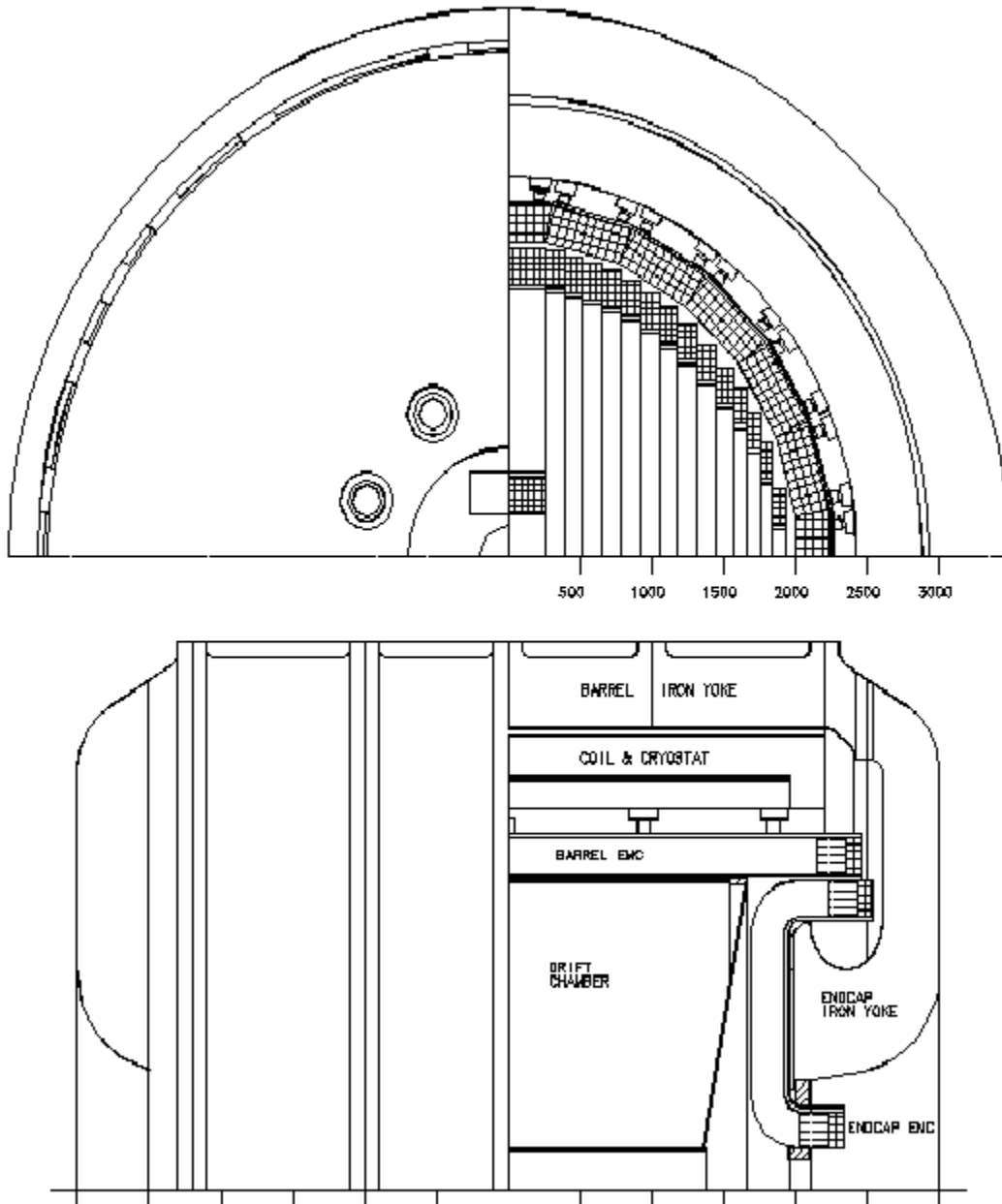

**Figure 10: front (top figure) and side (bottom figure) view of the calorimeters showing their light guides and their position relative to other KLOE sub-systems.**

## 6. IRON RETURN YOKE AND SUPERCONDUCTION SOLENOID

The yoke configuration is typical of collider experiments with a solenoid magnetic field. The ~ 600 ton total weight of the yoke was divided into 34 pieces of an average weight of 20 tons. These pieces are (see Fig. 11 and Fig. 12):

- 8 upper and 4 lower semi-shells plus 2 long, massive beams which connect upper and lower semi-shells to form the barrel yoke (the barrel is divided longitudinally into 4 mega-ribs, each made by a lower semi-shell, an upper left semi-shell and an upper right semi-shell);
- 4 half end caps, which form the yoke poles;
- end cap halves are pinned (two pin/half) with a 0.3 mm tolerance to 2 upper and 2 lower semi-rings, which interface the barrel with the end caps and allow a coarse relative alignment of barrel and end caps at **1 mm level**;
- 4 "small" semi-disks (1 for each half), which fill the central 0.7 m diameter hole of the end caps and are used for fine alignment of the poles with the main body of the yoke (and the solenoid once inserted) at **¼ mm level**;
- 4 platforms located on top of the barrel, each equipped with an engine and a large bearing to translate and rotate end cap halves;
- 4 wheels located at the extremities of the two iron beams to move the experiment along the rails in the hall and roll it into the DAΦNE collision hall in 1998.

The yoke was pre-surveyed at the end of construction at the INSSE firm with TC2002 + LGC in February 1997. This two-week measurement campaign was more a debugging of the yoke hardware and of the end cap opening procedure than a comprehensive survey of the entire yoke. Yoke reference targets (or marks, YRMs) were 25 mm diameter bores, machined on the iron at known positions. Due to the shortage of the number of YMRs in the initial yoke project, we added 35 YRMs (by soldering permanently on the iron 35 suited supports) and surveyed them with respect to machined YRMs. Locations of YRMs on the various yoke parts are shown in Fig. 12. Cylindrical magnetic supports of the screw-in type precisely machined were used to center 3D targets of 40 mm diameter in the YRMs. We measured and kept for future reference the barrel. We checked the correct positions of the large holes in the end caps through which 6 engines push and pull the installation plates supporting the end cap EmCs. We found a gross alignment error of 5 mm relative shift of the two end cap centers; we found 16 mm and 30 mm gross errors in the positions of the machined holes on one of the end cap halves.

Prior to yoke assembly at LNF, two important jobs were carried out in the KLOE hall: the installation of the experiment rails and the creation of a network of permanent survey points, which are described in appendix A.

The complete assembly of the yoke occurred for the first time at LNF, starting from March 1997. During the installation of the 2 iron beams with their wheels and the subsequent mounting of the barrel pieces, we used the TC2002 as a free station for true online alignment. At the end with LGC we found that the 14 barrel pieces were assembled with an average deviation of 0.7 mm with respect to the YRM measurement at INSSE. Note that barrel YRMs represent the yoke reference frame and axis. Construction then proceeded with the installation of platforms with end

cap engines/supports for the rest of April 1997. YRM positions surveyed with the TC2002+LGC in the reference frame of the permanent network were related to the local cartesian frame of the iron yoke by means of CHABA. We estimate an accuracy in YRM coordinates  $\leq 0.2$  mm. When the system for moving KLOE was tested by shifting the yoke and the cryostat back and forth by 1.5 m, the survey showed variations of YRM coordinates in the yoke frame consistent with our resolution.

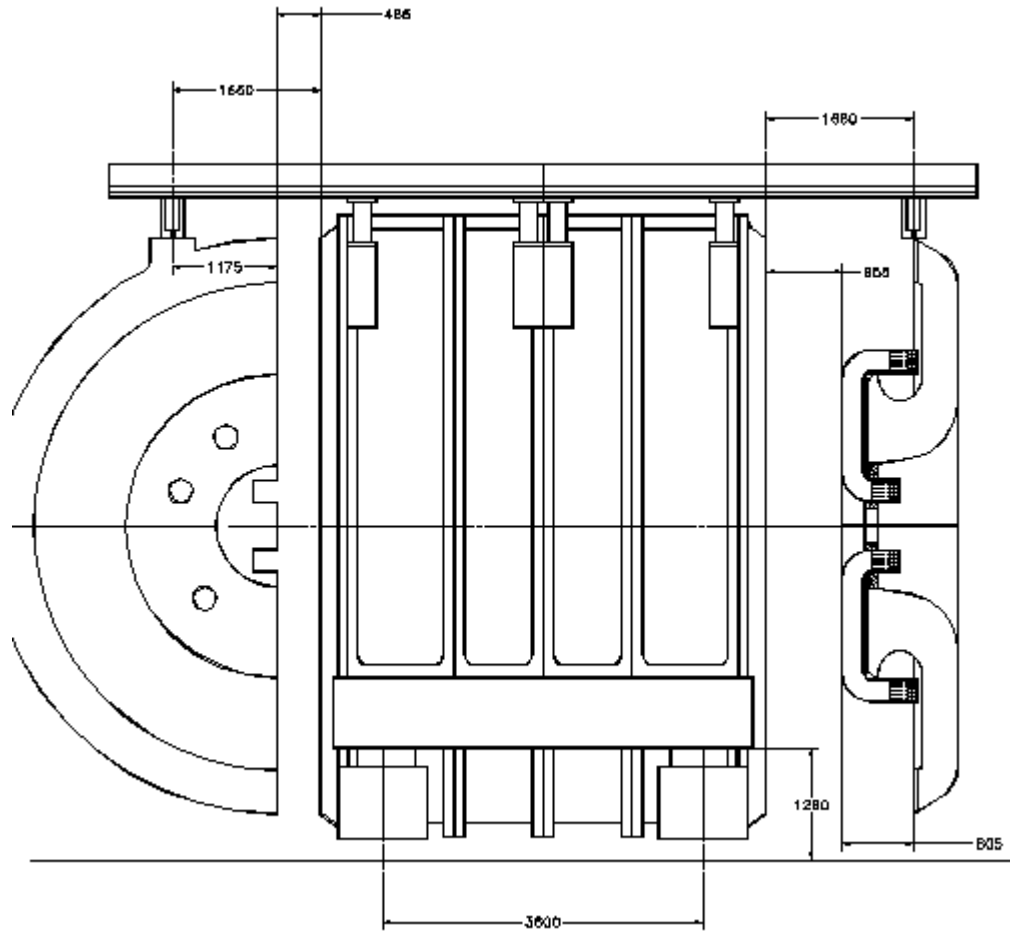

**Figure 11: side view of the KLOE iron return yoke, showing one half end cap opened (left) and one closed (right). At the center of the opened end cap, a semi-disk is visible with two square openings (on the right border of the semi-disk) to let out EmC cables as shown on the closed end cap. Not shown in the figure is the central semi-circular hole of the semi-disk for the beam pipe. The detailed shape of the semi-disks determines the exact configuration of the magnetic field at the poles. The 4 mega-ribs of the barrel are also clearly visible.**

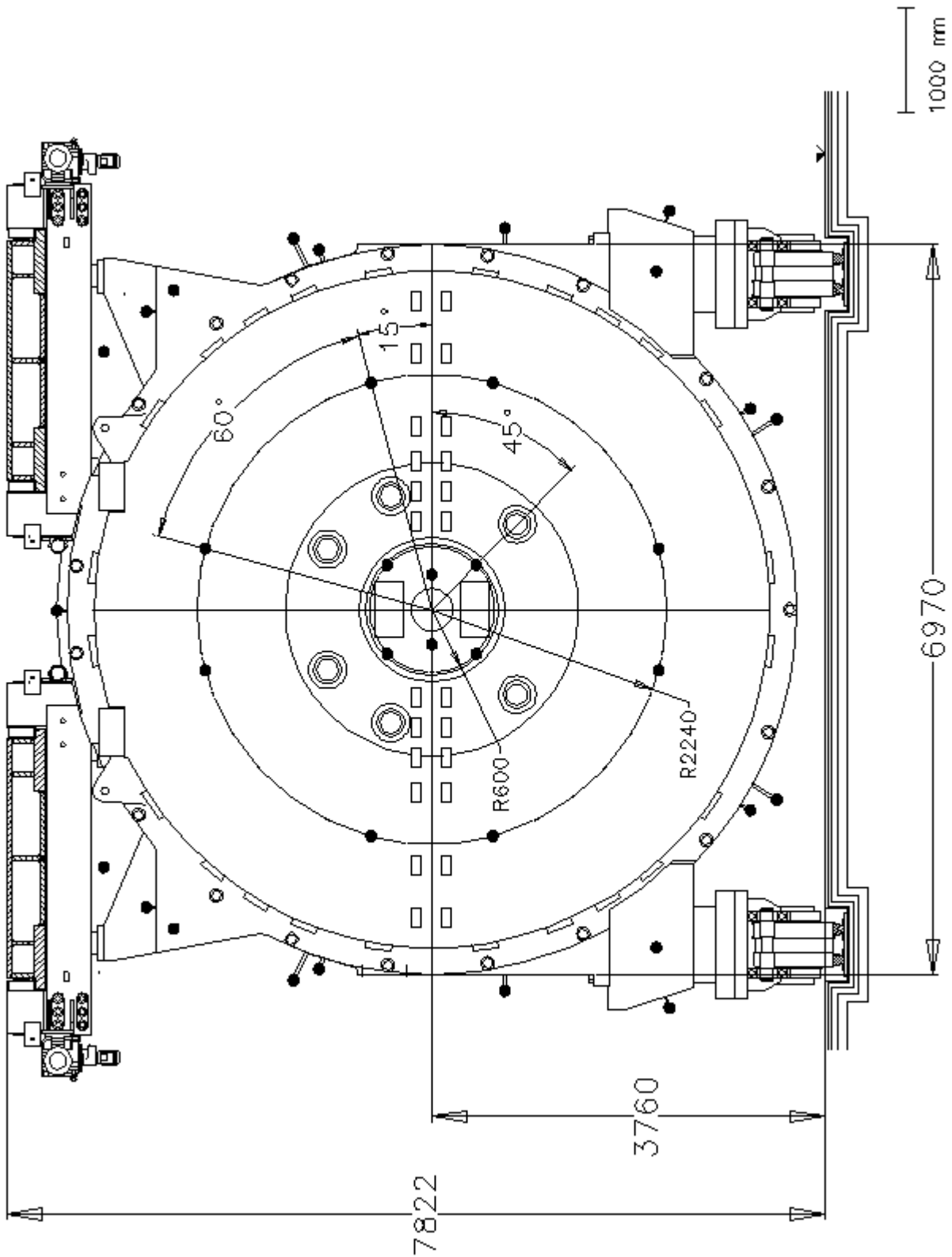

**Figure 12: front view of the KLOE iron return yoke showing the locations of reference targets (marks), the end-cap engine platforms and the wheels for rolling the experiment into the DAΦNE collision hall. The correct semi-disk geometry is shown.**

In early May 1997 the 40 ton cryostat of the superconducting solenoid was inserted into the yoke and the nominal *cold* axis of the coil aligned with the yoke axis using the TC2002 as free station, resected with respect to the YRMs. This was done by means of cryostat reference marks (see below), knowing their expected offset with respect to the magnetic cold axis. This information was stated by the manufacturer (Oxford Instruments) in the following terms: ``the coil position, when cold, measured from the end-face datum marks of the vacuum case is expected to be 2.9 mm above datum, 0.5 mm off vertical center line away from the power supply unit on the service turret side (STS) and 0.9 mm above datum, 0.5 mm off vertical center line towards the power supply unit on the non service turret side (NSTS)``. Cryo datum marks are 4 engravings (ECRMs) with about 1 mm thickness  $\times$  1 mm depth, located at right angles on the two end faces of the cryostat (4 ECRMs/face). Approximately centered on each ECRM there was also a threaded hole (which we will refer to simply as CRM), which we used to position our favorite 40 mm diameter 3D target pairs (4 CRMs/face). LGC showed a horizontal misalignment tilt of about 2 mm with respect to the yoke axis (corresponding to  $\sim 0.5$  mrad over the cryostat length of 4.4m).

The following steps were the alignment of the semi-rings on the barrel axis with a tolerance of 1 mm and the installation and pinning of the end caps on the semi-rings. After considerable optimization of the end cap opening and closing procedure, their centers in the closed positions were measured to be reproducible at  $\frac{1}{4}$  mm level and to be aligned with the yoke axis within 1 mm on average. The second and final alignment of the cryostat placed the coil axis parallel to the yoke axis within our accuracy ( $0.2 \oplus 0.2$  mm/4.4m  $\sim 0.1$  mrad) both in the horizontal (x) and in the vertical (y) direction, although with the offsets  $\Delta(y) = 0.5$  mm and  $\Delta(x) = 1.2$  mm. The two end cap planes were normal to the yoke axis, with a similar accuracy.

Finally, the 4 semi-disks, each with 3 YRMs, were mounted and their centers finely adjusted to coincide with the nominal axis of the coil and to make  $\Delta(y) = \Delta(x) = 0$  within the resolution quoted above, thus completing the installation and alignment of the system.

## 7. DIRECT MEASUREMENT OF THE POSITION THE MAGNETIC FIELD AXIS

Knowledge and control of KLOE's magnetic axis is important, given the tight alignment constraints imposed by the characteristics of DAΦNE's optics. The true position of the magnetic axis was measured by KLOE in August 1997 by means of a dedicated device built by the accelerator division. This measurement is a good check of the effectiveness of the alignment, similarly to the plot of the DC wire sagittae of Fig. 8.

This simple but effective machine measures the longitudinal field component and its r, z and  $\phi$  gradients. This is done by means of a single Hall probe, for  $0 \text{ mm} \leq \text{radii} \leq 170 \text{ mm}$  (the semi-disk circular hole has a 200 mm radius) and for a length  $|z| < 3.5 \text{ m}$  (about 1.4 m outside each semi-disk external face). Since all B field components are strongly coupled by Maxwell equations, the symmetry properties of  $B_z$  provides all information necessary to infer directly the position in space of the magnetic axis along the whole length of KLOE. In addition, once the axis location in space has been found, it easily provides the field integral for 7 m along that axis, which is necessary to DAΦNE's physicists. The information provided by the well-known CERN machine described in section 7, although three dimensional, is geometrically less accurate, which



is a disadvantage for studying the field shape where field gradients are large, like around the poles. Moreover, such machine only measures radii  $\geq 145$  mm and  $|z| < 1.9$ . Therefore, it not only does not access to outer regions where knowledge of the field is of some importance for accelerator operation: it does not measure the field at small radius and just in front and through the pole piece face. The radial component becomes here very large and small misalignments severely deteriorate the optics of the new low  $\beta$  insertion. Maxwell equations could allow determining the axis also with the data of the CERN *mapper*, but in a less direct and accurate way. In practice they are of no help in the extreme case of DAΦNE and KLOE. Given the relevance of the magnetic field axis information for the first collider factory to come online in the nineties, it was felt that a direct measurement was better suited. Note that, as reported in ref. [6], this measurement has never been performed by a general-purpose experiment before KLOE.

We refer to this device as MagAx (Magnetic Axis measurement device), and we describe:

- results of the standalone survey performed to assess its intrinsic geometrical properties,
- alignment and operation of the MagAx in KLOE.

## 7.1 Standalone survey

The MagAx main body is a precisely machined beam of about 7 m length, made of a special Al alloy. The 5mm×14mm flat encasing of the Hall probe is precisely positioned normally to the longitudinal axis, on the long front face of a 1cm×1cm×170 mm finger support. The probe can be positioned with a fixation screw at radii from 0 to 170 mm. The finger can be moved along the axis aligned along the nominal coil axis by means of a carriage, and the beam can be rotated azimuthally. All movements are performed manually. Conceptual designs with front and side views of the MagAx are shown in Fig. 13 and 14 to explain its working and alignment concept.

Fig. 13 shows the hall probe on its support, which rests on the movable carriage, which slides along an I-shaped beam. The large outer flange is fixed with screws onto the semi-disks of the KLOE yoke poles, while the inner flange supports the beam in its rotation about the longitudinal axis. On the rotating flange there are reference marks (6 mm holes) in which 3D targets of 26 mm diameter can be mounted. An intermediate alignment flange (not shown in the figure), which slides (thanks to special grease) in contact with the rotating flange, allows fine alignment of the beam in the transverse plane. This is done by acting with 6 screws on the alignment flange and displacing it with respect to the fixed flange and, therefore, with respect to the yoke semi-disks.

The MagAx was surveyed prior to its installation in KLOE by placing it on a long marble platform tightly constrained to simulate its final configuration. By pointing with the TC2002 a retro-reflective tape stuck on the probe protective case in order to measure 3D points we performed rotations and longitudinal scans of the 7 m length. Points. When needed, we pointed directly the marks printed on the probe encasing indicating the position of the sensitive area. We measured the following properties:

- the beam sagitta is about  $\frac{1}{4}$  mm over 7 m, in accordance with expectations;
- the beam is planar within  $\frac{1}{4}$  mm (which is basically due to its sagitta), and its plane is normal to the rotating flanges (where MagAx reference marks, MRMs, are located) within our measurement resolution;
- the two rotation centers of the rotating flanges are found by fitting circles through 6 positions tracked by MRMs (every  $60^\circ$ ); in the same way, by using the target on the probe, we determined the centers of 7 additional circles, located at the two z's of the rotating flanges, at three equidistant z's in between and at the two MagAx extremities. The fit of all circles in 3D is extremely good, with typical radial deviations  $< 0.1$  mm, and out-of-plane deviations of  $< 0.3$  mm. The straight line fit through these 9 centers is good and basically shows only the  $\frac{1}{4}$  mm vertical deviation due to the beam sagitta;
- the plane described by the probe marks, when the probe is translated in r and z, is offset from the rotation axis by 0.3 mm;
- when moved along r the probe stays normal to the longitudinal rotation axis within the survey accuracy.

These results guarantee that the MagAx is a rigidly moving object, geometrically accurate at the  $\frac{1}{4}$  mm level, adequate to satisfy its task.

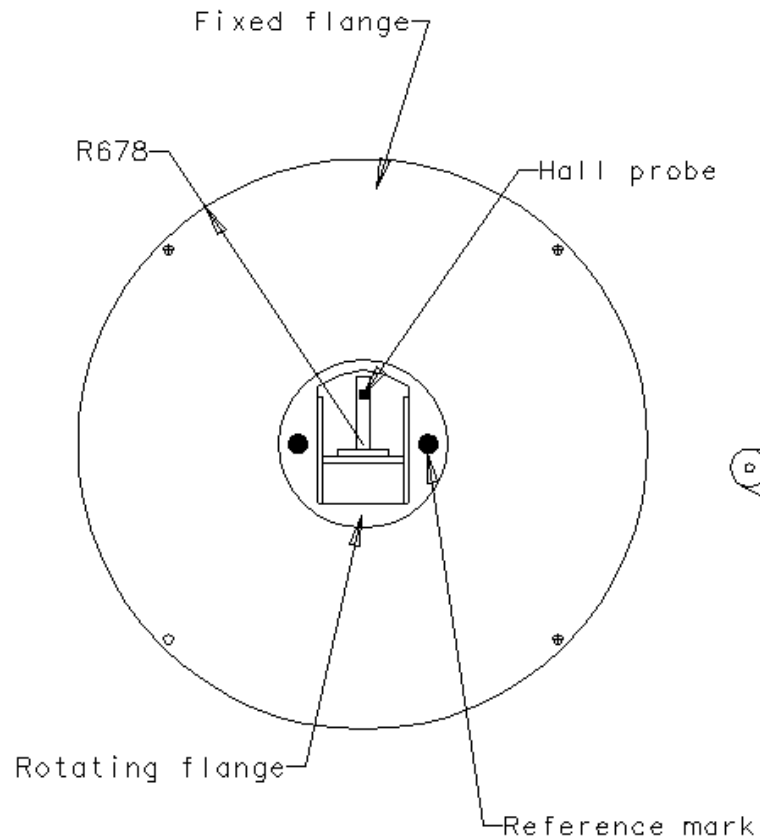

**Figure 13: front view of DAΦNE's MagAx.**

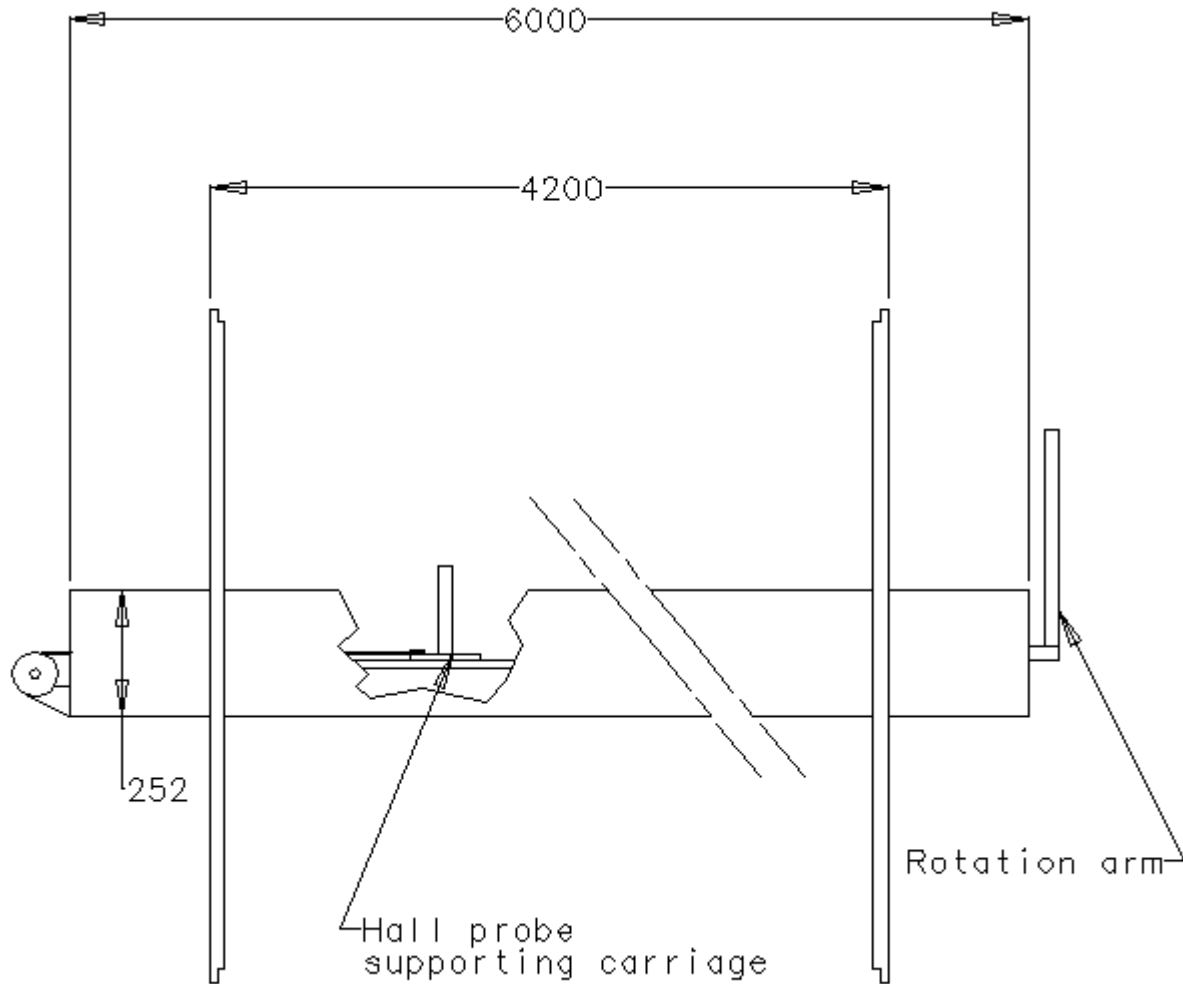

**Figure 14: side view of DAΦNE's MagAx, showing the pulley for longitudinal translation, the rotation arm (two of them, one for each side, are used in reality) and the overall approximate dimensions (total length available for measurements is actually 7 m).**

## 7.2 Alignment and operation in KLOE

Alignment of the MagAx in KLOE was achieved by positioning the fixation flange with 3 mm tolerance on the semi-disks, rotating the beam to find the x-y coordinates of the rotation center of MRMs and then finely adjusting the position of this center by displacing the intermediate flange (see Fig.13). The MagAx was aligned with the coil/semi-disks axis within 0.2 mm.

The magnetic measurement procedure was very simple and gave online the information of the magnetic axis position. We measured  $B_z$  at  $r = 0, 75$  and  $164$  mm, scanning  $\phi$  every  $45^\circ$  ( $90^\circ$ ) and  $z$  every  $50$  ( $100$ ) mm in the yoke poles (center). The radius of the probe with respect to its rotation center in the outermost position, which was precisely reproducible, was measured with

TC2002+LGC. The relative radial displacement in any other position was found simply but precisely with a ruler. Although the measurement is not very sensitive to  $\phi$ , this angle was determined with mrad accuracy by collimating two adjacent holes, one fixed and the other one on a marked disk rotating with the beam. Finally, by means of the TC2002 as a free station (approximately aligned with the yoke axis) pointing the retro-reflective target on the probe, we surveyed for each measured point the z coordinate, which was the only missing information. Knowledge of the KLOE z for all points was necessary in regions of high gradients (up to 16 G/mm) and to connect scans at different radii and at the same angle, since the pulley was not equipped with an encoder. In fact, the z position of the probe can vary due to:

- thermal dilatation of the 7 m Al beam (there is no thermal conditioning in the hall);
- non-trivial manual operation of the device in KLOE (which was more difficult than for the standalone survey);
- pulling of the probe readout cable.

The field value from the probe was read out via GPIB with a Macintosh computer running Labview, while  $\phi$  and z were entered manually into Labview. Inspection of the z and  $\phi$  symmetry properties of the gradients of the longitudinal field component,  $B_z$ , revealed that the measured magnetic axis was coincident with its expected position within experimental resolution. The following figures report preliminary results showing the quality of the alignment.

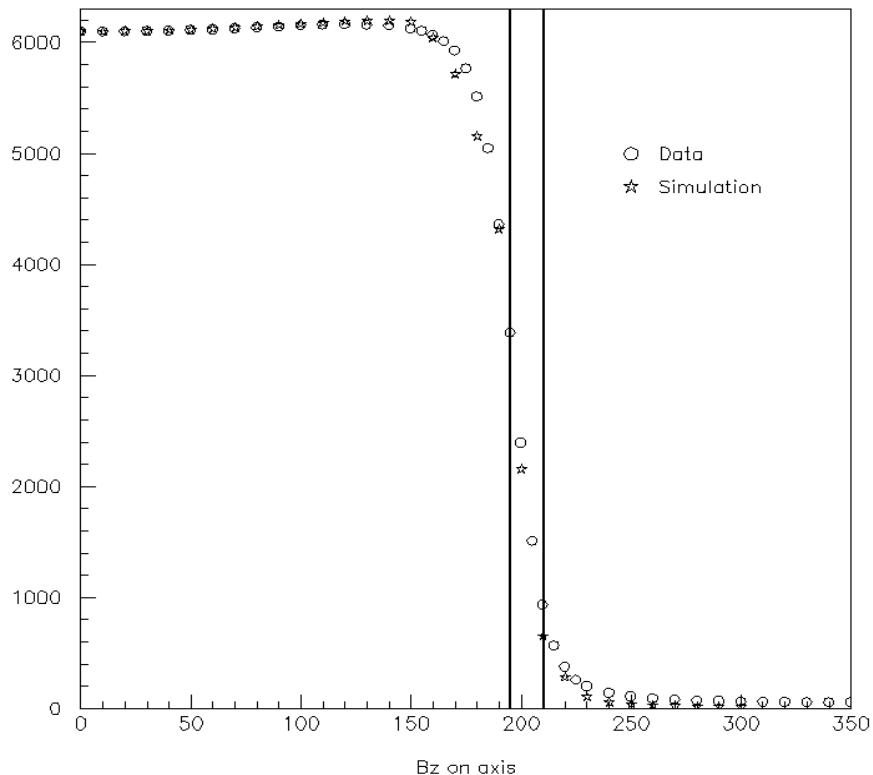

**Figure 15: KLOE's solenoid longitudinal field component ( $B_z$ , Gauss) along magnetic axis (z, cm) measured by the *MagAx*, compared with the MAGNUS Monte Carlo program.**

Fig. 15 shows  $B_z$  vs.  $z$  in the data and in the Monte Carlo. Note that larger gradients in the simulation curve are due to its cutoff at  $z=300$  cm from coil center. Vertical lines indicate the position of the yoke pole (inner and outer faces of the semi-disks). The KLOE drift chamber covers the region  $|z| < 150$  cm.

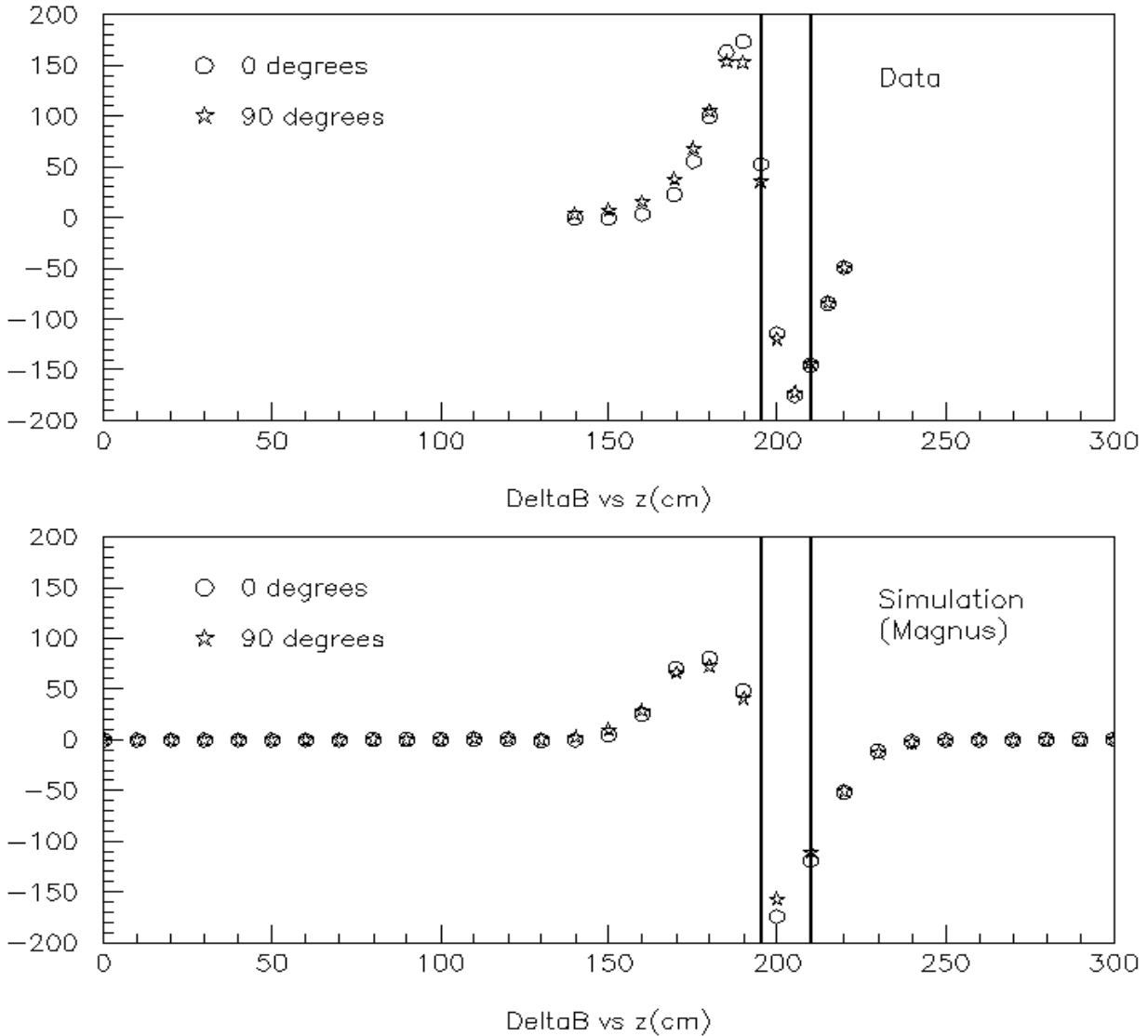

**Figure 16: KLOE superconducting coil. Difference of  $B_z$  (Gauss) measured on the magnetic axis with  $B_z$  measured at 7.5 cm radius from the axis versus  $z$  (cm).**

Fig. 16 shows  $\Delta B = B_z(r=0) - B_z(r=7.5 \text{ cm})$  vs.  $z$ . Differences between data points near the yoke poles at  $\phi=0^\circ$  (vertical direction) and  $\phi=90^\circ$  (horizontal direction) are due to different semi-disk geometry in the two directions (presence of rectangular holes at  $0^\circ$  and  $180^\circ$ ). Data are correctly modeled by MAGNUS. DeltaB in the data larger than Monte Carlo are due to the finer mesh of  $z$  measurements in the data; that is, Monte Carlo DeltaB are integrated in larger  $z$  bins, thus smoothing DeltaB.

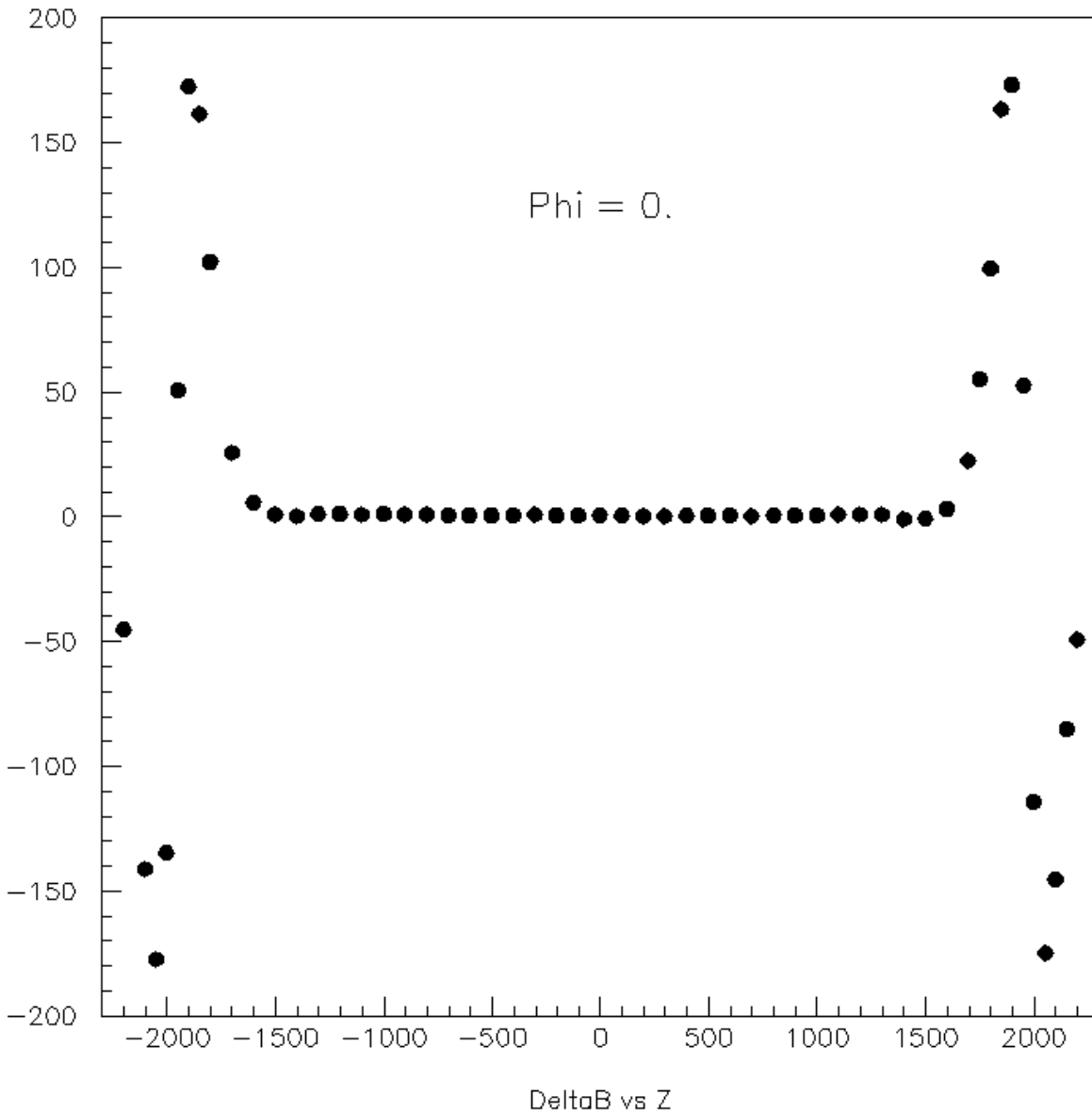

**Figure 17: KLOE superconducting coil. DeltaB (Gauss) vs. z (mm).**

Fig. 17 shows DeltaB vs. z up to 10 cm out of the external faces of the yoke poles. Note that positive and negative z's are only approximately equal in absolute value, which can be a relevant source of systematic error in regions where  $B_z$  gradients vs. z are large. For this reason the z coordinate is measured with the TC2002 infrared-beam distancemeter. The good forward (z<0) - backward (z>0) symmetry of DeltaB shows the good alignment of the MagAx with the magnetic axis of the superconducting coil produced by Oxford Instruments for KLOE.

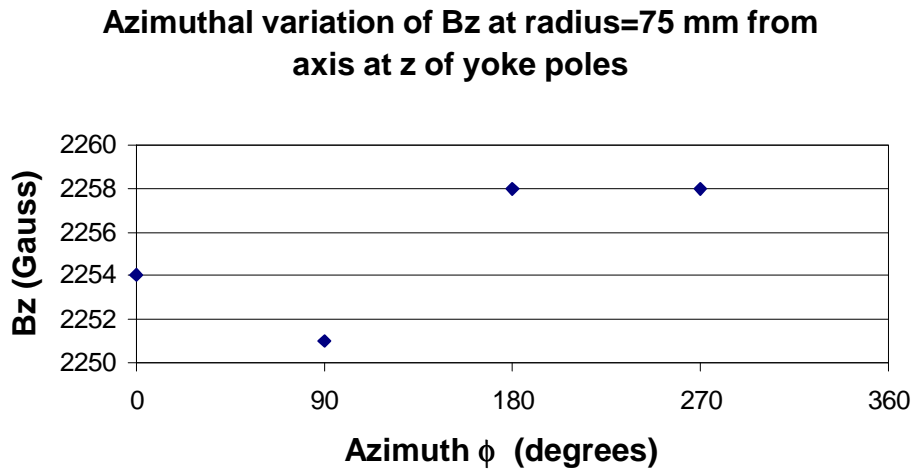

**Figure 18: the small measured  $\phi$ -asymmetry of the field longitudinal component  $B_z$  in the yoke poles (2 Gauss in the vertical  $0^\circ$ - $180^\circ$  plane and 3 Gauss in the horizontal  $90^\circ$ - $270^\circ$  plane with respect to averages).**

Fig. 18 shows  $B_z$  vs.  $\phi$  in the pole regions. This information, together with knowledge of  $B_z$  radial gradient at that  $z$  and  $r$  indicates that the true field axis is offset by 0.26 mm in the vertical plane and by 0.39 mm in the horizontal plane with respect to the axis of the MagAx. This is fully consistent with the quoted survey accuracy and the MagAx geometrical accuracy. The alignment accuracy of the KLOE superconducting solenoid is 0.1 mrad.

## 8. THREE-DIMENSIONAL MAP OF THE MAGNETIC FIELD

The full set of KLOE magnetic measurements was completed on October 9, 1997 with the 3D map of the inner yoke volume for radii  $> 145$  mm from the axis measured by the MagAx. Technical details and scope of mapping detector solenoids are by now well known and described in detail in the literature, for example in ref. [5]. Mapping was done with the CERN machine used for the OPAL experiment at LEP, slightly modified to be capable of reaching the region of EmC photomultipliers (in addition to the drift chamber tracking volume) in the pole regions. The shape of the field in the poles is relevant because photomultipliers are sensitive to magnetic field components normal to their axis of the order of 300 Gauss. To cover the full volume the machine needs to be reversed, and an overlapping region must be measured to normalize and connect positive and negative  $z$  volumes. One NMR probe located at the center of the device gives the absolute normalization of our field and cross-calibrates other two Hall probes permanently positioned in the middle and at the end of the cryostat inner surface. Variations of the field value, will be monitored in the future with these two Hall probes.

A detailed survey of this machine showed that its geometrical accuracy and alignment tolerance is  $O(1)$  mm in length and  $O(1)$  mrad in angle, adequate for mapping the DC and photomultiplier regions. The solenoid was mapped at about 6, 4.5 and 3 KGauss. After inversion and re-alignment of the machine we found a  $B_z$  normalization error of 0.05 % in the  $|z| < 0.8$  m overlap region.

Analysis of the data started already at the time of data taking to check for possible faults in the installation and operation of the mapper. Preliminary results indicate that the measurement has been successfully accomplished, that photomultipliers will operate undisturbed by the magnetic field and that data from probes at small radii, although geometrically less accurate, are consistent with MagAx measurements.

## 9. CONCLUSION AND ACKNOWLEDGEMENTS

The construction and installation of KLOE required the creation of a dedicated survey and alignment facility in the LNF Research Division. The work reported in this review was completed by a manpower of 3 FTE in little less than two years and it was successful, as all task requirements were satisfied. This achievement would not have been possible without the support of P. Franzini and S. Bertolucci. We owe to G. Capon and J. Lee-Franzini helpful suggestions and comments on the content of this review.

We are indebted to M. Mayoud, C. Lasseur, J.C. Gayde and T. LeMaire of the CERN survey group for helpful teachings and suggestions, for one month of hands-on training experience at CERN and for providing KLOE with LGC and CARNET. We learnt a lot on subjects related to the construction of the KLOE drift chamber and iron yoke from G. Petrucci of CERN, who was KLOE consultant in the critical phase of the experiment design.

We thank F. Iungo and G. Delle Monache of the LNF Accelerator Division for their help in the preparation of the magnetic measurements and for the design and construction of the MagAx, respectively. We especially thank G. Vignola, Director of the LNF Accelerator Division and of the DAΦNE project, for his supervision and encouragement during the actual performance of the KLOE magnetic axis measurement.

## 10. REFERENCES

- [1] The KLOE Collaboration, *The KLOE Detector, Technical Proposal*, LNF-93/002.
- [2] The KLOE Collaboration, *The KLOE Central Drift Chamber, Technical Proposal*, LNF-94/028.
- [3] S. Dell'Agello et al, *Status of the Construction of the KLOE Drift Chamber*, Nucl. Phys. B (Proc. Suppl.) 54B (1997) 57-65; S. Moccia, *The KLOE Drift Chamber End Plates*, KLOE public note (October 1997).
- [4] V. Elia et al, *Stringing of the KLOE Drift Chamber at LNF*, Nucl. Phys. B (Proc. Suppl.) 54B (1997) 66-69.
- [5] D. Newton, *The Magnetic Field Mapping of Detector Magnets*, Proc. of the CERN Accelerator School, Montreux, Switzerland, March 1992.
- [6] D. Newton, *Detector Magnet Measurements*, Proc. of the CERN Accelerator School, Anacapri, Italy, April 1997.



## APPENDIX A: EXPERIMENT RAILS AND PERMANENT SURVEY NETWORK

Two important accessories of the assembly hall are:

- the experiment rails, positioned in November 1996 with an alignment tolerance of 0.5 mm horizontal co-planarity and 1.0 mm parallelism/straightness;
- the permanent survey network, which we installed and measured in March 1997.

The rails consist of orthogonal short and long segments. They cross in the middle of the hall forming a 6.4 m by 3.6 m rectangle. The long segments were laid running from the hall towards DAΦNE, with their vertical symmetry plane coincident with the vertical median plane of the accelerator passing through KLOE's interaction region. The origin of the network reference system is approximately at the center of the rails' rectangle and it is located at about 32 m horizontal distance from the center of DAΦNE. The network y axis is vertical, the x axis is horizontal and it is approximately coincident with the vertical symmetry plane of the long rail segments. Note that, while sitting on the rails, the center of KLOE is about 1.5 m lower than its final location in DAΦNE. A non-trivial lifting/alignment system is under construction for positioning KLOE on the beam line.

The network consists of 20 survey points, half at ground level and half at a vertical level of about two thirds of KLOE's height (~ 5 m). Six of the survey points at top level were brackets for standard CERN reference targets of the non-foldable type, since they were located in positions accessed only by surveyors. The remaining network points were instead of the removable type, since they had to be positioned in high traffic. The KLOE assembly hall is so small that we could not even afford using foldable brackets, which are so common in the LEP experimental halls at CERN. On the contrary, the brackets we adopted (made of anodized Al) are mounted by means of their two pins and three precisely machined 2cm×2cm flat contact surfaces on a 2 cm thick Al plate fixed to the wall. The bracket has a 30 mm precision hole with a 120° chamfer, which can accommodate a Taylor-Hobson target (and any other of our 3D targets by means of suited "rallonges"), the TC2002 and the Distinvar. The manufacturer guarantees that the distance of the 30 mm holes of two such brackets can be measured with the invar/Distinvar with a systematic error due to the Distinvar pulling force <0.1 mm. This is about a factor 2 worse than the error typical of this technique and it applies to the worst case of the invar wire stretched normal to the brackets. These removable brackets also have a separate 10 mm diameter hole which can accommodate a Taylor-Hobson with a special support and the TC2002 thanks to a special accessory for TC2002 forced centering (an index is engraved on the surface of the bracket). The special support and the special accessory are sold together with the bracket plus plate. These brackets are very versatile objects, which we systematically mounted/dismounted before/after almost every survey (one of them got hit and the pins damaged when we left them in position). We also moved them often from one plate to the other since we bought 5 brackets but bought and installed 14 fixed plates. The drawback when using these objects is that each plate has to be fixed carefully to the wall in such a way that the 30 mm and 10 mm holes are vertical, as no alignment in this direction is possible after their installation, differently from CERN-style reference-target brackets.

With LGC we estimate the accuracy in the determination of the position of the network points as  $\leq 0.2$  mm. The naming and the coordinates of all network points are given in KLOE internal memo 121.

By the time of KLOE's installation in DAΦNE the network will be about 14 months old. So far we did not observe *sinking and aging* effects of the network. We did, however, observe a 1.8 mm movement along the rails of the KLOE yoke + solenoid with respect to the network, following the series of earthquakes which occurred in central Italy in October and early November 1997.