

A New Hydrostatic Leveling System Developed for the Advanced Photon Source*

*Lassi A. Kivioja, Horst Friedsam, Merrick Penicka
Argonne National Laboratory, Argonne, Illinois, USA*

1. INTRODUCTION

All hydrostatic level systems (HLSs) use water or some other liquid to provide an absolute elevation reference for measuring elevation changes. Usually several measurement stations are interconnected with tubes providing a path for the liquid between individual vessels. Existing HLSs differ mainly in the measurement concept used to detect changes in the liquid level, which is equivalent to measuring the elevation change of a particular vessel. Depending on the required accuracy, ultrasonic sensors, touch probes, and capacitive sensors are used to record these changes. In this paper a new method of measuring and recording the changes of a liquid surface is proposed. In this case the free upper surface of a liquid is used as an optical reflector (Fig. 1).

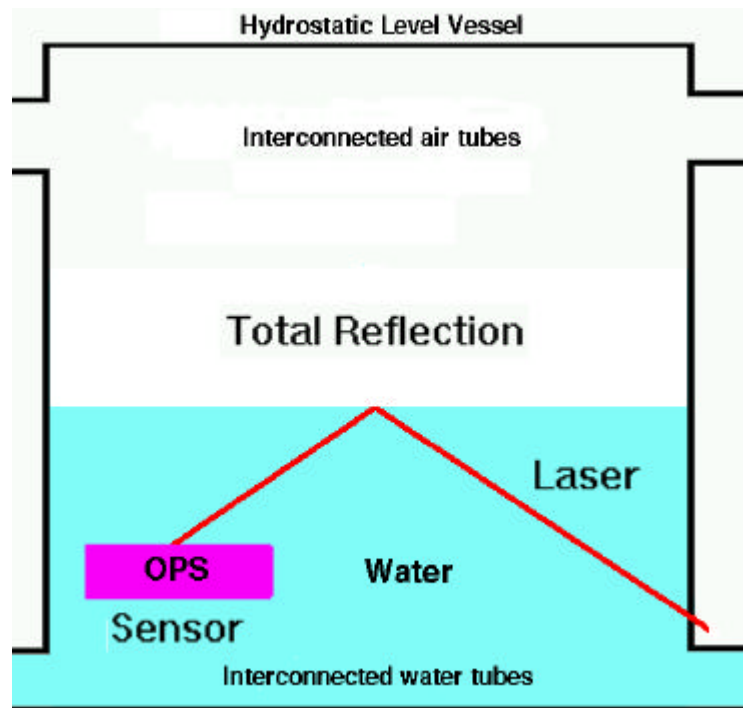

Fig. 1. Principle of the new HLS

Common distilled water is used to provide an absolute reference system for detecting elevation changes at each vessel location. In order to measure these changes, a thin laser beam is sent into the water-filled container through an optical window. After a total reflection from the upper free liquid surface, the laser light produces a spot on a linear optical position sensor (OPS) mounted at the bottom of the container. When the liquid level changes, the reflected light beam moves to another position on the sensor. Changes in liquid levels can be measured with an accuracy better than 1 micron. Some prototypes using this schema were built and tested at Argonne for the Advanced Photon Source (APS).

* Work supported by U.S. DOE, Office of Basic Energy Sciences under Contract No. W-31-109-ENG-38.

Two or more hydrostatic level vessels are interconnected by water and air tubes. Once the system has been properly filled with the liquid, the water level will become a part of the same equipotential surface in all vessels. In order to eliminate the effects of trapped air in each vessel, all hydrostatic level containers have been interconnected with air tubes providing the same air pressure to all vessels. The distilled water is usually treated with chemicals to prevent the growth of fungi and algae during the operation of the system.

2. HLS PROTOTYPES

Development of this new type of hydrostatic leveling system started at Argonne National Laboratories in May 1992. Working prototype units became available for testing and calibration in April 1993.

2.1 Liquid containers

This system consists of liquid containers that are interconnected by almost horizontal water tubes filled with distilled water such that the water depth is almost the same in all vessels. For test purposes the containers can be individually raised or lowered and leveled to achieve this configuration (Fig. 2). In order to assure that the water surface in each container is experiencing the same gas pressure, the gas volume above the water in each container is interconnected to the adjacent vessels using gas tubes. Under these conditions the center of the upper free water surface in each container is a part of the same equipotential surface, or surface of constant dynamic height, if the density of the water is the same in all containers. Because the density of water depends on its temperature, a thermocouple is placed into a horizontal hole drilled from the edge of the bottom plate to the center just under the bottom of water in each container (Fig. 3). Using this temperature information, the water level in each container can be corrected as necessary. It is well known that the thermal coefficient of expansion of water is 0.0002 per 1° Celsius at 20° Celsius. This results in a change of 2 μm per one 1° Celsius for a water column with a depth of 1 cm. Similarly, the possible volume change of the vessels due to thermal effects must be considered.

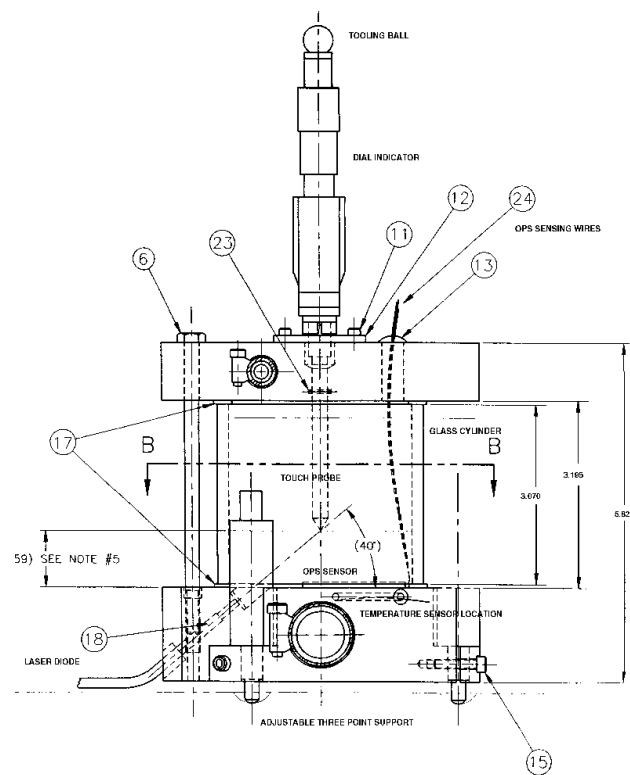

Fig. 2. Cross section of an HLS vessel.

2.2 Height measurement of the liquid level

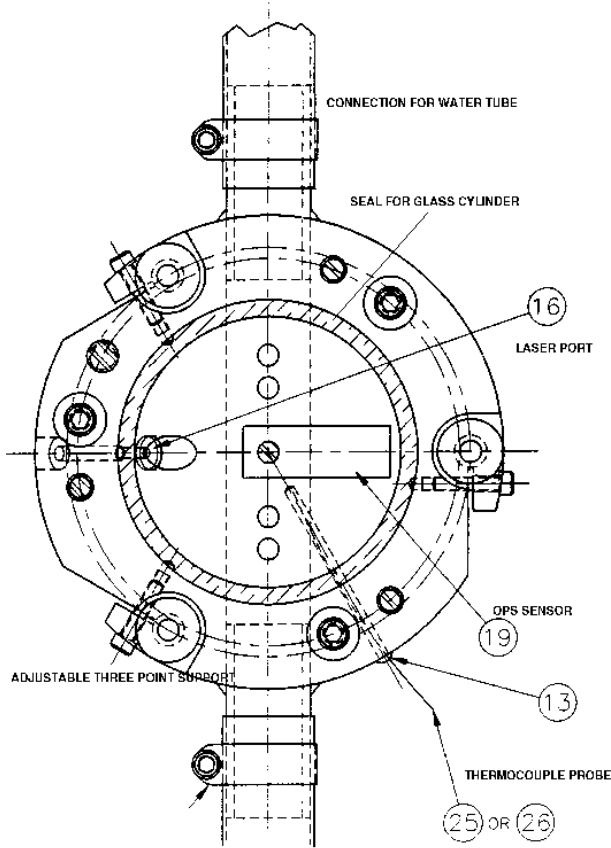

Fig. 3. Bottom plate of an HLS vessel.

The height of the upper free surface of water is measured in each container by a light-sensitive optical position sensor (OPS). These sensors are also available in versions that can function in high-UV environments and nuclear power plants. A stable, parallel beam of light, emanating, for instance, from a low power (1 to 2 mW) diode laser, enters the water through a waterproof optical window and travels through the water toward the water-air interface at a vertical angle of 40 degrees above the horizon (Fig. 2). The laser beam forms an angle of 50 degrees with the surface normal of the water. Because this angle is greater than the critical angle of 48.8 degrees for the water-to-air interface, a total reflection of the laser beam takes place. The laser beam is reflected back through the water onto the OPS, where it produces a voltage corresponding to the spot location. The OPS is covered with a thin glass plate and, therefore, not all of the incident light is absorbed. Instead, some of the laser light is reflected back into the water and to the container walls. These multiple reflections are undesirable for this application because multiple

spots could be created on the OPS, resulting in false readings of the actual elevations.

The length of the sensitive surface of the OPS in this design is 30 mm. If the water level increases by one millimeter in elevation, the reflected spot on the sensor travels an additional 2.3835 mm. The depth of the water over the sensor is approximately 18 mm when the light beam strikes the center of the sensor. The water depth is approximately 12 mm when the light beam strikes the near end of the sensor, and approximately 24 mm when the light beam strikes the far end of the sensor. Therefore, the maximum operating range in this design for measuring the water level is approximately 12 mm. Other operating ranges are possible by suitably choosing the angle of reflection, length of the OPS, and the size of the container.

Depending on the chosen voltage range of the OPS, the 12-mm change in the water level produces a measurable voltage range of 20 V or 15 V, respectively, when the reflected light beam travels from one end of the sensor to the other end. A good operational range for the water depth in this design is between 21 and 15 millimeters, which corresponds to a travel range of ± 7.6 mm of the 30-mm sensor surface, near its midpoint.

The manufacturer of these sensors claims that the sensors have a submicron accuracy for sensing the position of the light spot where the laser beam strikes the sensor. They also claim that

should the light beam intensity, wavelength, or the spot size vary, the normalized output of the OPS will remain constant. This is a very important and advantageous property of this OPS. It means that a constant water level can be indicated even if the intensity, wavelength, or spot size of the laser source shows slight variations.

Finally, it is important that the chosen 40-degree angle in this design stays constant for each vessel. However, this angle may vary slightly but cannot exceed 41.2 degrees because of the requirements for obtaining a total reflection. Small deviations from 40 degrees will cause a slightly different calibration value for each leveling unit, which will be determined during the calibration process.

3. CALIBRATION

Several methods for calibrating an HLS vessel have been developed and tested for this system. The following sections describe some of these methods in detail.

3.1 Calibration using a micrometer probe

A micrometer touch probe has been successfully used in other HLS designs to measure the elevation of the water column in individual vessels. Although this prototype design accommodated a micrometer probe, this method was not used for calibration purposes. It could have provided another check for the results of the other calibration methods.

3.2. Calibration by a controlled elevation change of one vessel in a system of two units

The three leveling screws on the containers in this design are actually standard micrometer screws (Fig. 2). One full turn of a micrometer screw results in a change of elevation of 1.27 mm. These micrometers can be used to level a vessel or to raise or lower it by a known amount.

For example, consider that two identical vessels, A and B, are properly interconnected by water and air tubes. The laser beam in the prototype units will produce a spot near the center of the sensor if the water depth over the sensor is 18 mm for each unit. From this position, raise or lower one of the units 1.27 mm using its three micrometer screws. Raising unit A will cause some of the water to flow from A to the stationary identical unit B until the water levels are equal in both units. Theoretically the water depth will decrease by 0.635 mm in A while it increases by the same amount in B. Water depths are then 17.365 mm in A and 18.635 mm in B. In unit A, the reflected spot of the laser beam travels 1.514 mm in one direction from the center location while in unit B the reflected laser spot travels the same distance in the opposite direction. For the 30-mm-long 20-V sensor, this produces a calculated voltage change over the 1.514-mm distance along the sensor of 1.009 V ($1.514 \text{ [mm]} \times 20/30 \text{ [V/mm]}$). This same voltage change also applies for the actual water level change of 0.635 mm, which gives 1.589 V/mm for the 0.635-mm water level change in units A and B. Similarly, the 15-V sensor produces a voltage change of 1.192 V/mm per 0.001 mm change in the water level. If the angle at which the laser beam enters the liquid is not exactly 40 degrees, these numbers will change.

In a preliminary calibration performed in June 1993, unit A was raised in eight successive 0.635-mm increments for a total of 5.08 mm, then lowered by four 1.270-mm increments to return to the starting level. Then the unit was lowered by eight successive 0.635-mm increments and finally raised by four 1.270-mm increments to arrive at its original elevation. The corresponding voltages of the optical position sensors for units A and B were read after each incremental change. Unit A was thus moved up and down over a total range of 10.16 mm, and its water level changed over a total range of 5.08 mm, first down by 2.54 mm and then finally up by 2.54 mm. When the water level went down in A, it went up in B by the same amount, and vice versa. Once the readings had stabilized after each incremental change in elevation of unit A, the voltmeters were read and recorded. In actual usage, vibrations of the ground and the support system produce vibrations of the water level. Therefore, an average of a few hundred voltage readings over a period of time should be used to represent the best reading.

The entire procedure of calibrating these two units took about 34 minutes. The calibration values of the voltmeter Fluke 97 were not known. Unit A was found to produce 1.17 ± 0.02 mV/ μ m for the water level changes, and unit B 1.32 ± 0.02 mV/ μ m. As mentioned earlier, the angle at which the laser light enters the liquid may not have been exactly 40 degrees and could be the cause for the difference in the scale values for the two units.

More than two units can be calibrated by this method of raising and lowering one unit by a known amount s . If there are n units and one of the units is raised by a distance s , its water level goes down by $s(n-1)/n$ while the water level in each of the other units rises by s/n . There are other somewhat similar calibration methods. For instance, one unit could be raised and another unit could be lowered by the same amount. In this case, the remaining units should display their same original elevations when the water level has stabilized after this disturbance.

3.3 Calibration using an auxiliary water reservoir

Another calibration method for a large number of vessels is the use of a reservoir with a known volume containing the same liquid as the HLS and connected to the closed system via a valve. This reservoir is placed on a platform that can be leveled, raised, and lowered so that its free upper water surface is at the same elevation as the water level in all the leveling units. This reservoir could be installed outside of the accelerator housing, providing easy access for monitoring and calibration purposes even during machine operation times.

The size of the reservoir to serve, for example, 200 of the described prototype units with water containers 8 cm in diameter should be such that 10 liters of water can flow out of or back into the reservoir. This volume of reservoir would be more than enough to calibrate all leveling units over ± 10 mm water depth changes starting from the center position of the laser beam on the OPS of each leveling unit. Recording the voltage output of all sensors in the system will produce data that can be used to calibrate all leveling units at once.

3.4 Calibration by adding a known amount of water

As previously mentioned, the diameter of each prototype container is 8 cm. Adding one cubic centimeter of water to a single container raises the water level by 0.1989 mm. Adding one cubic centimeter of water to two interconnected vessels raises the water level by 0.0995 mm in both containers. For example, if the system contains 200 units, adding one cubic centimeter of water raises the water level in each vessel by 0.995 μm . Consequently, a 10-liter reservoir provides a water level elevation changes of 9.95 mm per unit. This method provides the means to calibrate all vessels at once, when a known volume of the liquid from the reservoir is added or subtracted from the system, assuming that all vessels are stable during the calibration process.

4. CONCLUSION

As a result of the calibration tests performed with the first prototype units using the new measurement principle, we believe that the described leveling method is stable and accurate to the micron level with a sufficiently large range for the expected elevation changes of the support girders used in the APS storage ring. Although long-term studies with this system have not been conducted, we believe that after installation this system requires little or no servicing for long periods of time. The methods described in this paper cover only the elevation changes of individual vessels. However, changes in the tilt of a girder must also be known. Therefore, a combination of tiltmeters in conjunction with this HLS would be most suitable for measuring the tilt and elevation changes of the APS girders.