

TEST RESULTS OF THE BBA METHOD AT THE TRISTAN ACCUMULATION RING

*K. Endo, H. Fukuma and F. Q. Zhang**
National Laboratory for High Energy Physics (KEK)
** The Graduate University for Advanced Studies*
1-1 Oho, Tsukuba-shi 305, Japan

Abstract — According to the algorithm of the beam-based alignment, the quadrupole displacement was given by generating the local orbit bump at an individual quadrupole and then the orbit distortions were measured with the beam position monitors all around the Accumulation Ring (AR). Preliminary studies give the promising results with an accuracy comparable to or exceeding the conventional method if the position monitor is accurate as 0.01 mm or better. In this work the relation between the offsets of the quadrupole magnet and readings of the beam position monitors were examined by both experiment and computation.

1. INTRODUCTION

According to the beam-based alignment (BBA) algorithm introduced at IWAA95 [1], the preliminary orbit measurements were performed for TRISTAN-AR (Accumulation ring) using an improved electronic current shunt which is an alternative of the resistive shunt [2]. The simplified linear equations were applied to the BBA measurements. In the experiments the sextupole magnets were powered to eliminate the chromatic aberration to assure the higher beam intensity in AR. The beam orbits were corrected horizontally and vertically with the steering magnets and the backleg windings to the tolerable distortions.

The BBA method can be conveniently applied to the measurement of the transverse magnet displacement after the accelerator begins the beam operation. As the slight modulation of an individual quadrupole magnet current would not interfere with the physics experiment, this kind of measurement could be done periodically or when it is requested during the routine operation of the machine.

The transverse displacements of only one quadrupole can be measured at a time, so the same procedure is repeated for all quadrupoles. If the electronic current shunt is remotely multiplexed for all quadrupoles, the procedure can be programmed and the orbit perturbation due to the current modulation can be measured automatically. For this purpose the amount of the current reduction is controlled by the field-effect transistor (FET), not by the resistor because the shunted current is determined by the voltage balance across the resistor and quadrupole in the latter method. In the former method the resistance of the electronic shunt can be controlled easily by applying a voltage signal to the FET which allows an easy control of the shunt current.

2. LINEAR RELATION FOR THE BBA METHOD

The orbit distorts due to the current perturbation given to a quadrupole magnet to reduce the excitation current by passing a part of current to a shunt attached parallel to the magnet current terminals. If there is a transverse offset of the position of the quadrupole from the beam center, the deflection strength to the beam is proportional to this offset.

If $\{\Delta y\}$ and $\{\xi\}$ is a beam position displacement column vector and a magnet offset column vector of either horizontal or vertical plane, respectively, the following matrix relation is obtained when the n-th quadrupole current is reduced by κ % [1, 2],

$$\{\Delta y\} = (B)\{\xi\},$$

where B is a MxN matrix whose elements are

$$B_{mj} = \frac{\sqrt{\beta_m \beta_j}}{2 \sin \pi v} \frac{G_j l_j}{B \rho} \left\{ \left[\frac{\Delta \beta_m}{2 \beta_m} + \frac{\Delta \beta_j}{2 \beta_j} - \frac{\pi \Delta v}{\tan \pi v} \right] \cos v \Phi_{mj} - [\Phi_{mj} \Delta v + v \Delta \Phi_{mj}] \sin v \Phi_{mj} \right\} \quad \text{for } j \neq n,$$

and

$$B_{mn} = \frac{\sqrt{\beta_m \beta_n}}{2 \sin \pi v} \frac{G_n l_n}{B \rho} \left\{ \left[\frac{\Delta \beta_m}{2 \beta_m} + \frac{\Delta \beta_n}{2 \beta_n} - \frac{\pi \Delta v}{\tan \pi v} + \frac{\kappa}{100} \right] \cos v \Phi_{mn} - [\Phi_{mn} \Delta v + v \Delta \Phi_{mn}] \sin v \Phi_{mn} \right\} \quad \text{for } j = n$$

$$m = 1, 2, 3, \dots, M, \quad j = 1, 2, 3, \dots, N.$$

$\Delta \beta$, Δv and $\Delta \Phi$ are the differences of the betatron function, tune and phase advance, respectively between the perturbed and non-perturbed optics,

$$v' = v + \Delta v, \quad \beta_j' = \beta_j + \Delta \beta_j \quad \text{and} \quad \Phi'(m; j) = \Phi(m; j) + \Delta \Phi(m; j).$$

$\Phi_{mj} \equiv \Phi(m; j)$ is the phase advance between the m-th monitor and the j-th quadrupole. G_j and l_j are the field gradient and effective length of the j-th quadrupole. Suffices m and j stand for positions of the beam monitor and quadrupole, respectively.

The matrix elements, B_{mj} and B_{mn} , are given from the numerical calculation of the lattice parameters for the perturbed and non-perturbed machine. Above relation is obtained for both horizontal and vertical plane independently assuming that the coupling does not exist between the horizontal and vertical motions. To eliminate the orbit distortions existing in the AR before applying the current shunt to any quadrupole, only the additional orbit distortions are derived by subtracting the original closed orbit distortion (COD).

3. CURRENT SHUNT SYSTEM FOR THE EXPERIMENTAL COD MEASUREMENT

The former FET shunt has been modified to adapt for any magnet, especially for the low coil voltage, as shown in Fig.1. The FET shunt uses the metal oxide semiconductor field-effect transistor (MOSFET) connected parallel to the magnet coil and the current shared to the shunt is specified by the reference signal. A part of the exciting current of the quadrupole is shunted through FET while it is conducting. The shunted current is limited by the saturation of MOSFET and the present model FET shunt can allow the max. 25 A. The max. current duration 60 sec is limited by the temperature rise of the FET. So we must wait for at least 60 sec after each operation. The shunt current was measured with a digital multimeter. The current drift was negligibly small, less than 0.1%, during 60 sec. This duration time was determined to collect readings of all position monitors.

At least a unit of this current shunt is incorporated into the accelerator control system as shown in Fig.2 to predict the quadrupole misalignment. If the current shunt is applied to every quadrupole sequentially for a short time during the BPM readings, it is possible to predict the individual misalignment from a complete set of the BBA data.

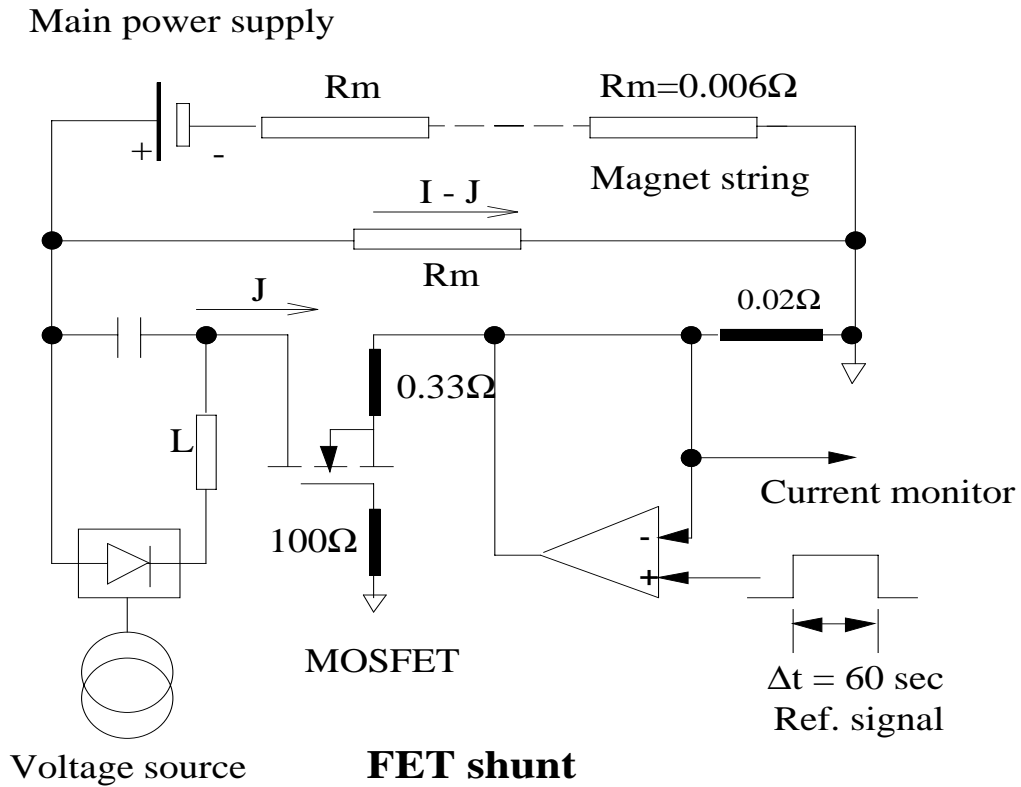

Fig.1 Modified FET current shunt equipped with the voltage source.

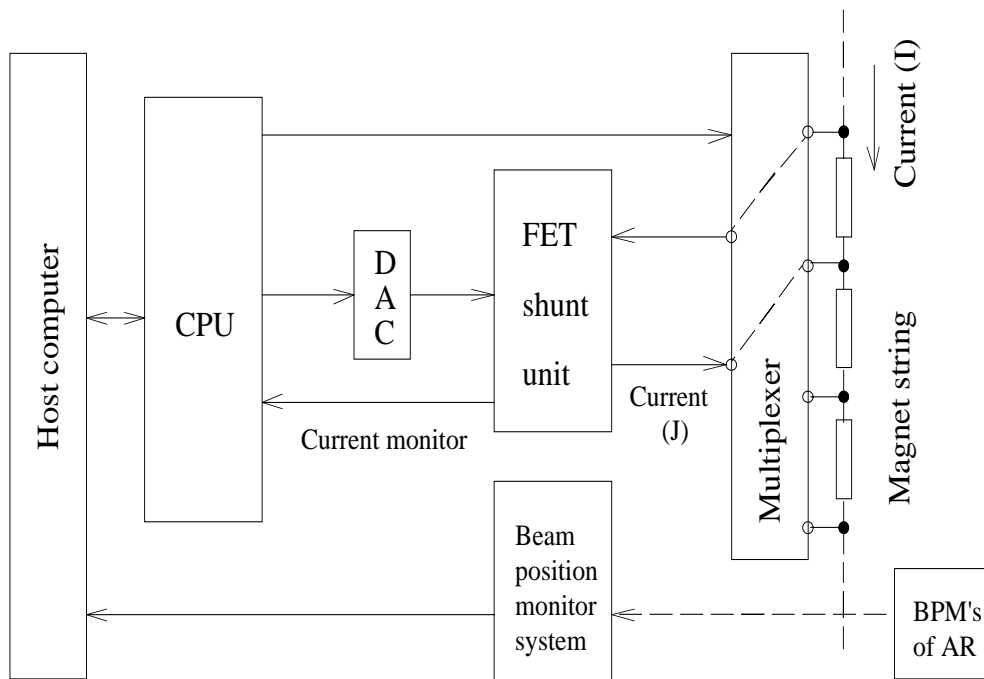

Fig.2 The computer controlled current shunt expected for the BBA system. DAC = Digital-to-Analog Converter, BPM = Beam Position Monitor, FET = Field-Effect Transistor, and CPU = Central Processing Unit.

4. EXPERIMENTAL COD MEASUREMENT

The AR ring is currently shut down to convert it into the dedicated SR (Synchrotron Radiation) source. This experimental study of the BBA method was performed last year for a very short time just before the AR shut-down.

The beam positions were measured with the button electrodes equipped in the AR ring. In order to estimate the present accuracy of the beam position monitors, the same COD measurements were repeated several times. The differences were plotted as in Fig. 3 and Fig.4 for the horizontal and vertical COD's, respectively. The accuracy was $\pm 30 - 50 \mu\text{m}$ except for several monitors in both planes. The present accuracy is not enough for the BBA which is expected to detect the misalignment less than $50 \mu\text{m}$ or so.

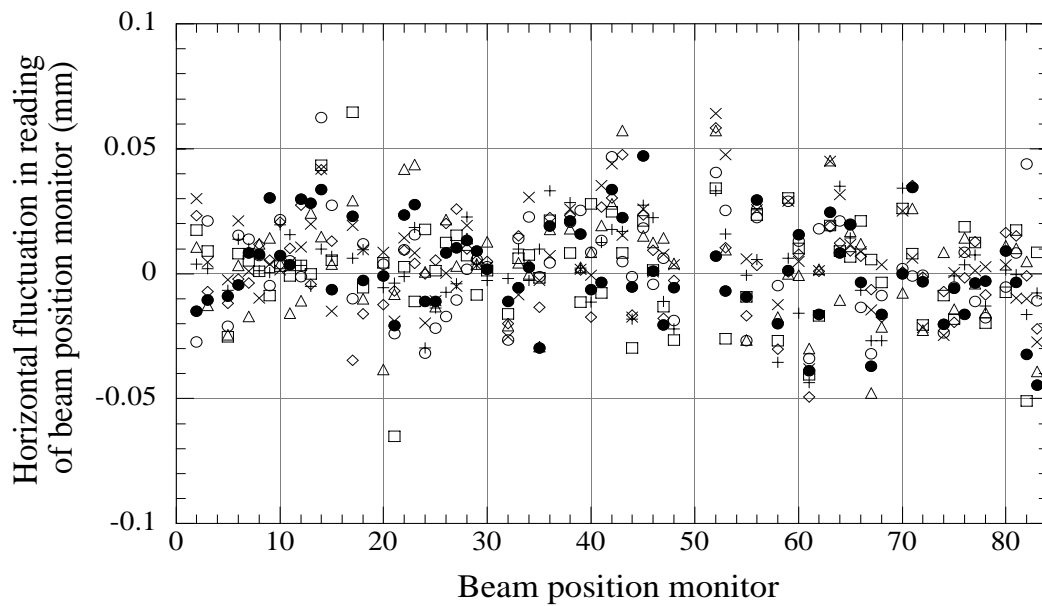

Fig.3 Accuracy of the horizontal COD measurements

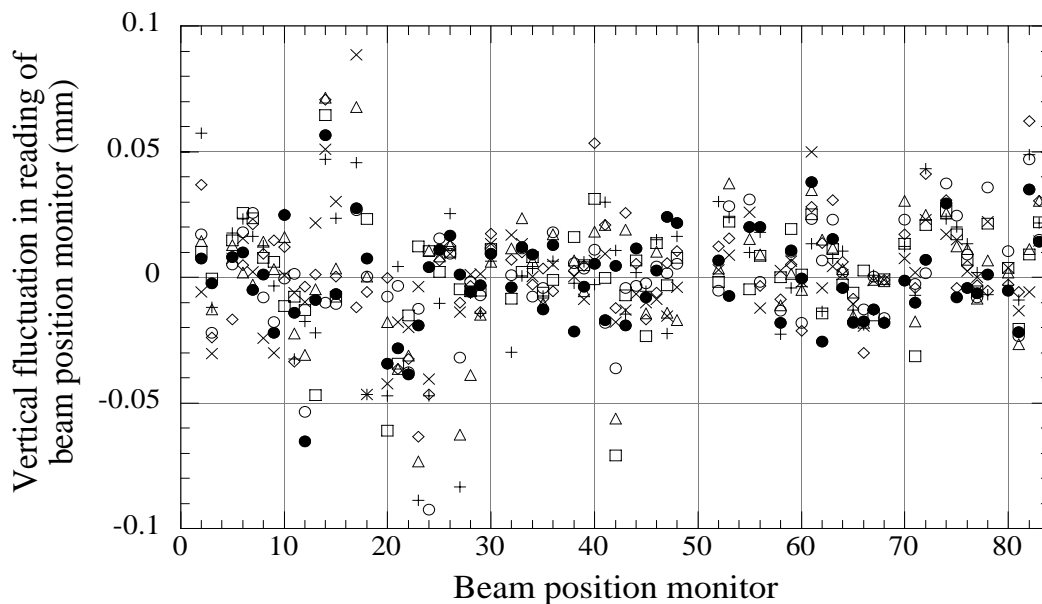

Fig.4 Accuracy of the vertical COD measurements.

As for an effect from the transverse kick to the vertical COD and vice versa, the local orbit bump was set so as to demonstrate the quadrupole misalignment and the COD's of both planes were measured simultaneously. Fig.5 and Fig.6 are the effects to the horizontal and vertical orbits, respectively, due to the horizontal kick at the selected quadrupole (QR6NW, focusing quad) by reducing the current by 3.11% at injection. Similar effect to the vertical and horizontal orbits due to the vertical kick at the another quadrupole (QR5NW, defocusing quad) by reducing the current by 2.43% at injection as shown in Fig.7 and Fig.8. In these measurements the side-effect to the other planes (coupling) is an order smaller than the principal planes, so it is safe to say that the horizontal kick has an effect only to the horizontal offset and the vertical kick to the vertical offset.

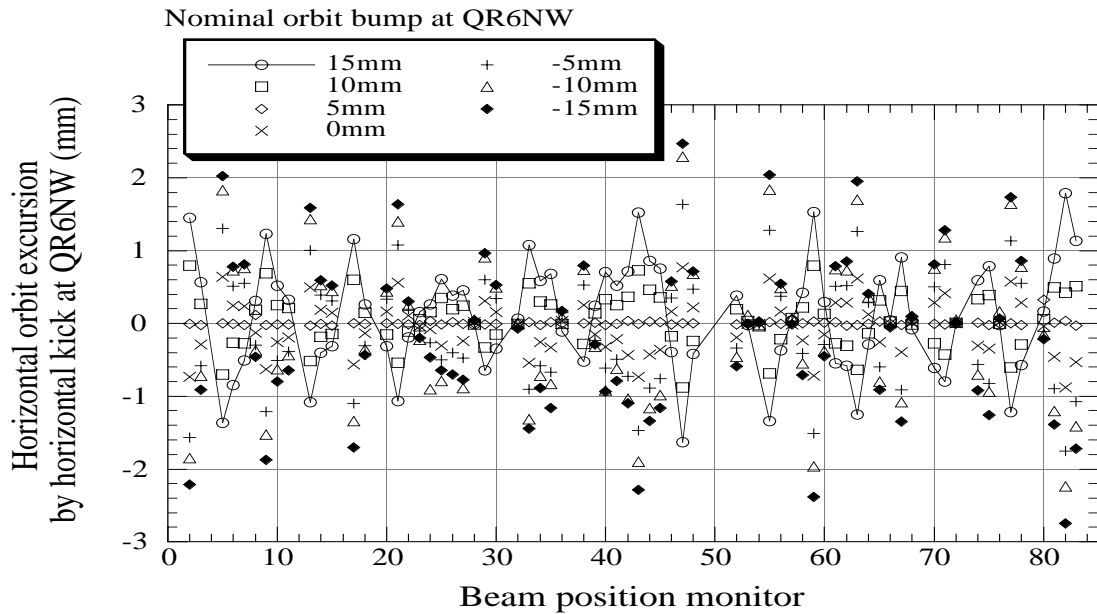

Fig.5 Horizontal closed orbit due to the horizontal kick at the QR6NW quadrupole. Kick was given by the current reduction by 3.11% when the offset was horizontally given by the local orbit bump at this quad.

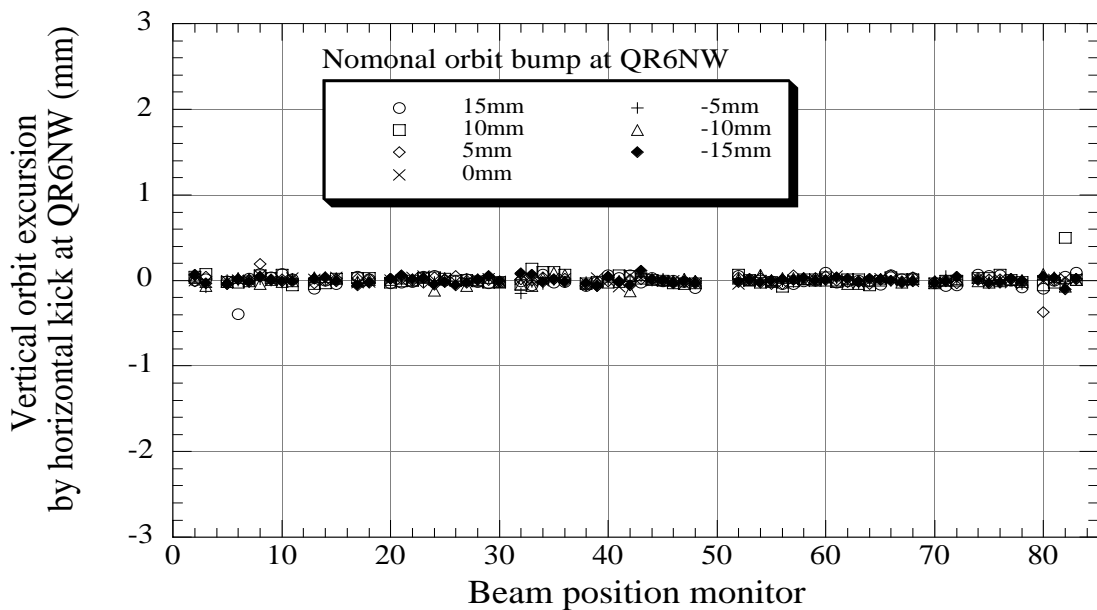

Fig.6 Vertical closed orbit due to the horizontal kick at the QR6NW quadrupole. Kick was given by the current reduction by 3.11% when the offset was horizontally given by the local orbit bump at this quad.

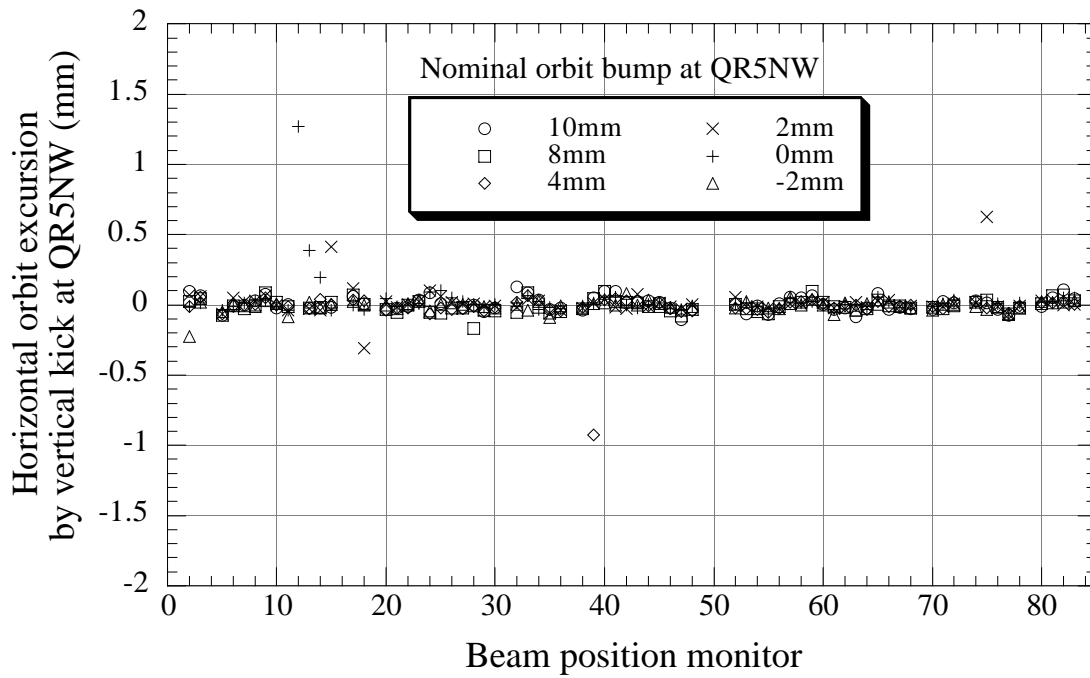

Fig.7 Horizontal closed orbit due to the vertical kick at the QR5NW quadrupole. Kick was given by the current reduction by 2.43% when the offset was vertically given by the local orbit bump at this quad.

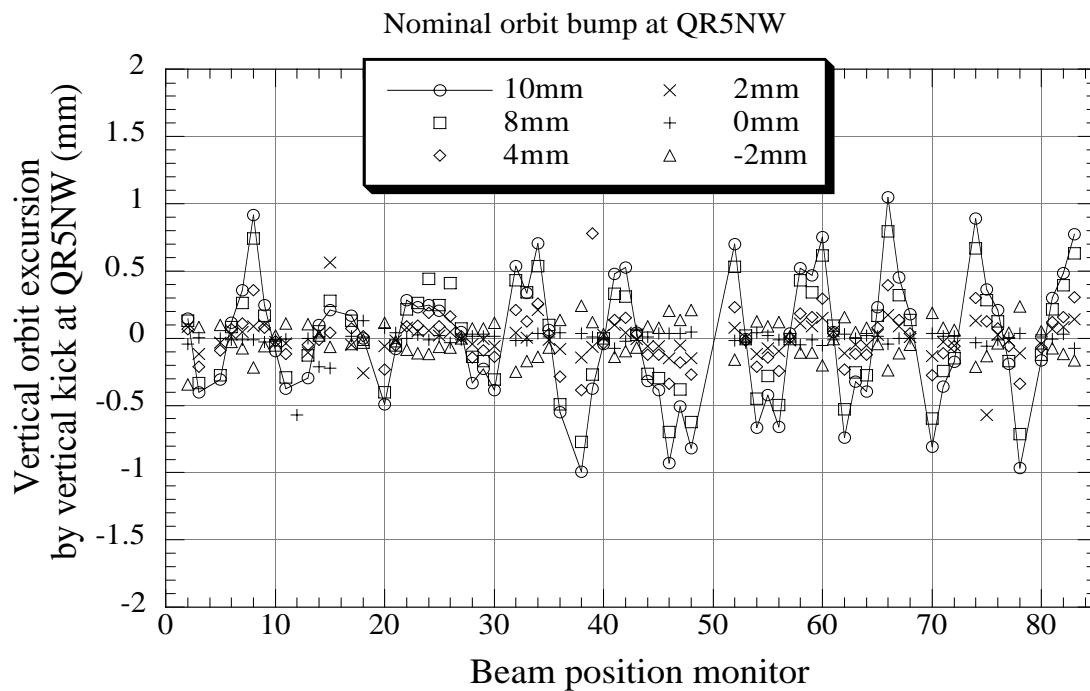

Fig.8 Vertical closed orbit due to the vertical kick at the QR5NW quadrupole. Kick was given by the current reduction by 2.43% when the offset was vertically given by the local orbit bump at this quad.

The nominal local orbit bump shown in Fig.5 ~ 8 should be calibrated as in Fig. 9 and Fig.10 horizontally and vertically.

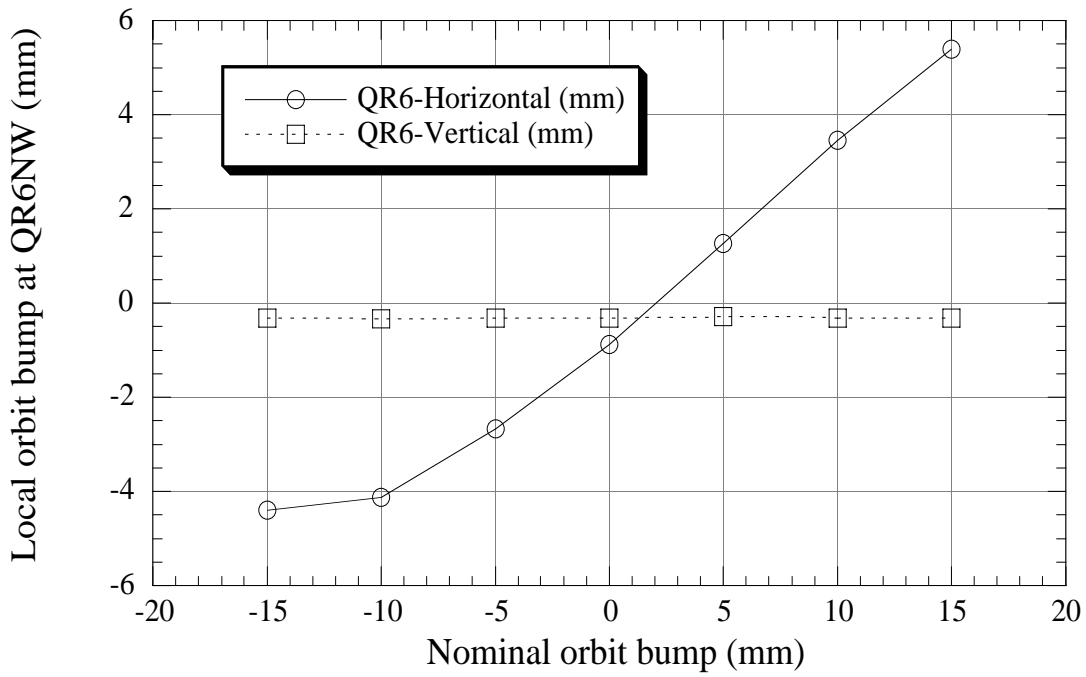

Fig.9 Calibration curve for the local orbit bump at QR6NW. Horizontal offsets are given by the open circles. Almost no change was observed for the vertical orbit given by open squares.

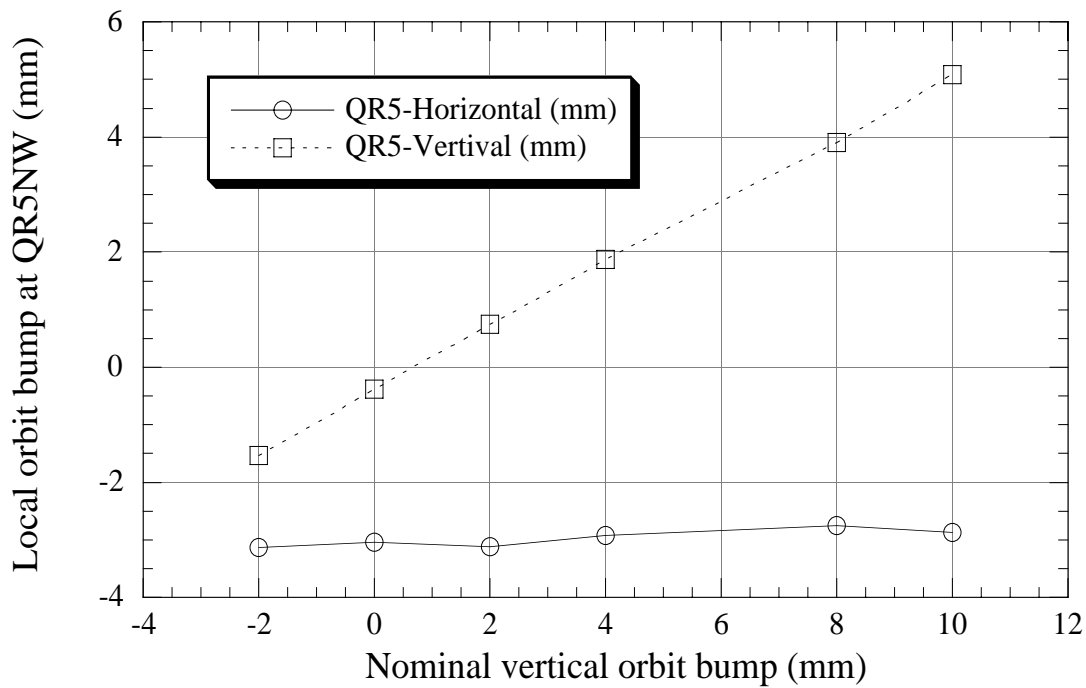

Fig.10 Calibration curve for the local orbit bump at QR5NW. Vertical offsets are given by the open squares. Almost no change was observed for the horizontal orbit given by open circles.

5. COMPARISON BETWEEN THE NUMERICAL PREDICTION AND THE MEASURED PERTURBED ORBIT

The expected readings of the beam position monitors are obtained by the numerical simulation by assuming the real machine and operation parameters. Two optics, with and without a current shunt to a specified quadrupole magnet, are calculated using a MAGIC like optics code which has been developed for this purpose. The current bypassed through the FET shunt was measured and the percent reduction (κ) was considered in the simulations. In this study only two quadrupoles, QR5NW and QR6NW, were assumed to have the vertical and horizontal offset, respectively, and all beam position monitors were read.

During the orbit measurement the chromaticity was corrected with the sextupole magnets. Under this situation the orbit might distort at sextupoles, so the beam had received the deflection depending on the distance from the magnetic center (sextupole axis). Assuming the sextupole as a thin lens ($k_{SXF} = 0.9 \text{ m}^{-2}$ and $k_{SXD} = -1.8 \text{ m}^{-2}$ for the focusing and defocusing sextupole, respectively), the equilibrium orbit is calculated repeatedly. After about 10 repeated calculations the equilibrium orbit is established but almost no effect was obtained from sextupoles as shown in Fig.11.

In simulations the random misalignments are assumed for all quads except for a quad under consideration and the perturbed orbit due to the offset of the quad is the orbit difference after and before the current reduction. The same procedures were applied to the orbit measurements.

Comparisons are undertaken between the measurement and the numerical computation. They show an excellent agreement as shown in Fig.11 and Fig.13. If we select several beam position monitors that will give an transverse offset estimation, the linear relations are obtained as shown in Fig.12 and Fig.14 for the horizontal and vertical offset, respectively.

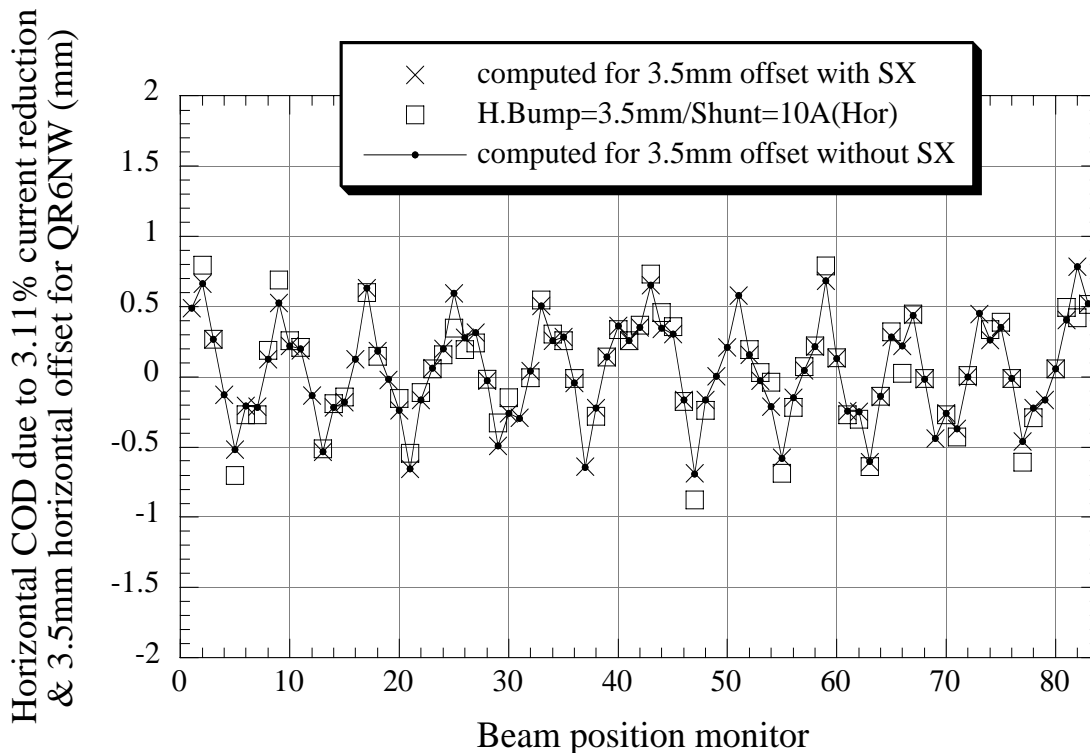

Fig. 11 Comparison of the horizontal COD between the measurement and calculation for the horizontal offset of 3.5 mm and the current reduction of 3.11%. Crosses give the results when the sextupole effects are considered.

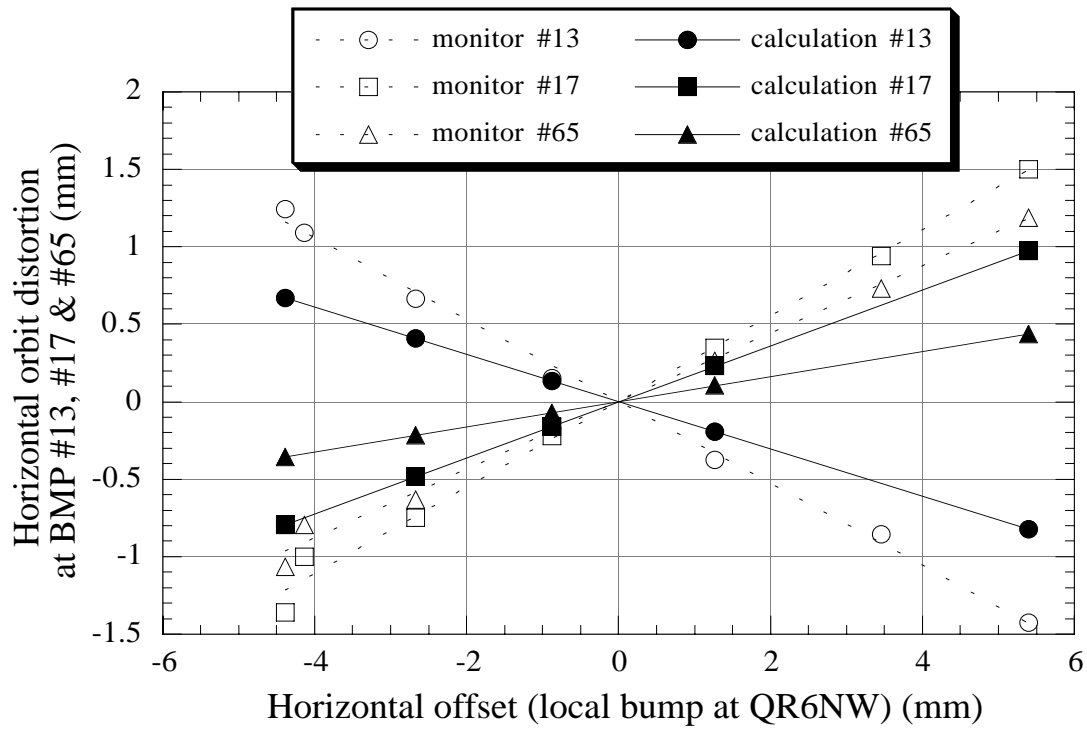

Fig.12 Horizontal orbit excursions observed at BPM #13, #17 and #65. Solid lines are computation and dotted ones measurement. Monitor readings were shifted vertically to cross the origin.

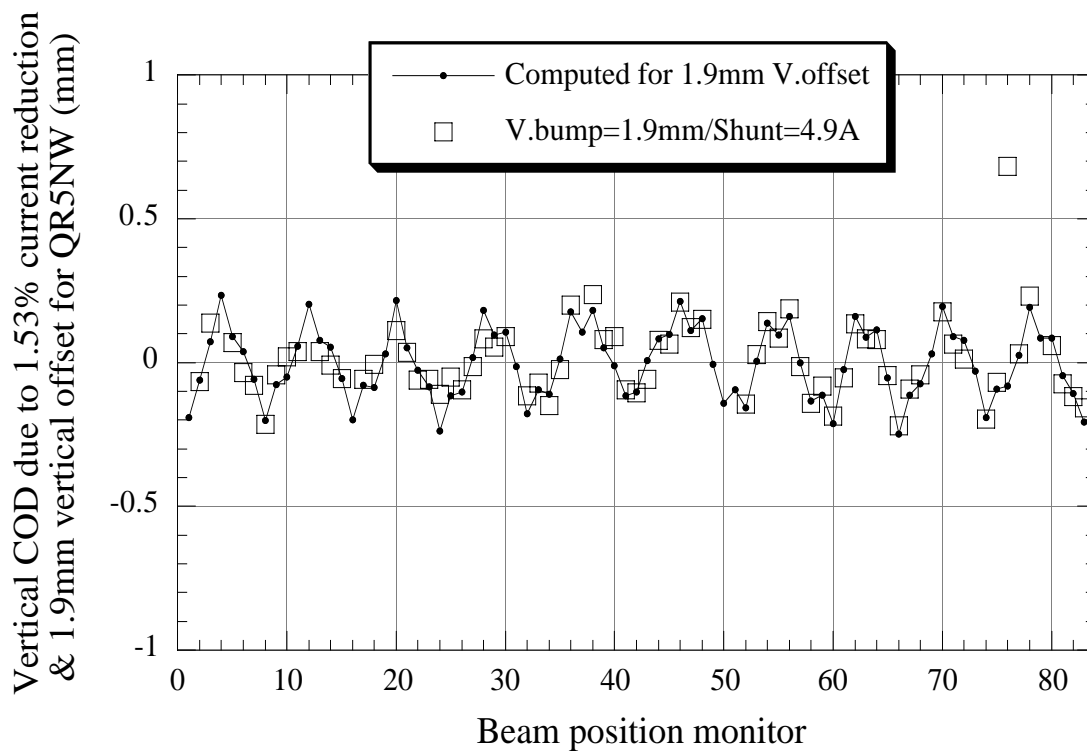

Fig. 13 Comparison of the vertical COD between the measurement and calculation for the vertical offset of 1.9 mm and the current reduction of 1.53%.

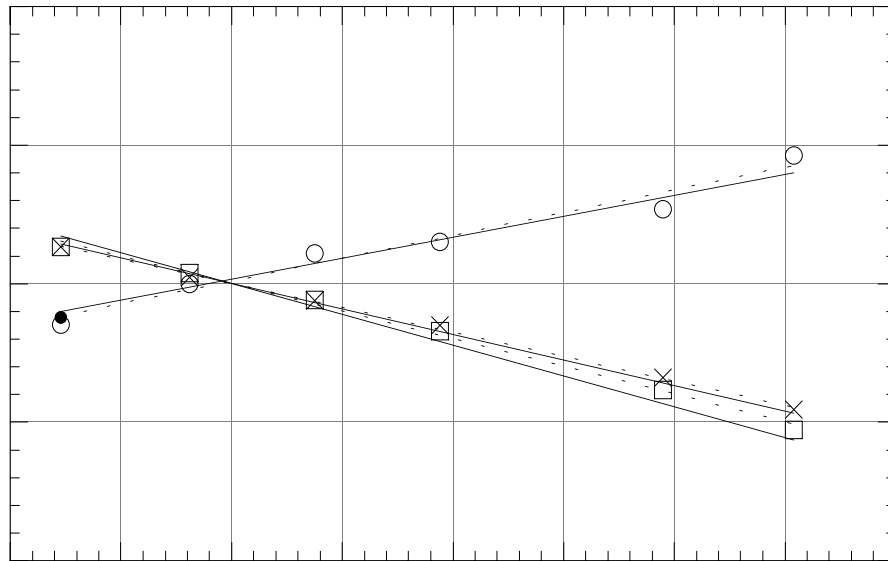

Fig.14 Vertical orbit excursions observed at BPM #34, #46 and #70. Solid lines are computation and dotted ones measurement. Monitor readings were shifted vertically to cross the origin.

6. CONCLUSION

From Fig.12 and Fig.14, the BBA method can predict the quadrupole magnet misalignment of $20 \sim 50 \mu\text{m}$ if the BPM reading is as accurate as $5 \mu\text{m}$. However, discrepancy between the measurement and calculation must be calibrated according to the present local bump method. In the real case of the BBA method, it is enough to use small number of the calibrated BPM's. Present study adopted all available monitors and gave rather unrealistic large offset for the sake of obtaining the BBA data under the noisy measurement condition. In practice offsets are very small, so the accuracy of BPM is very important to get the useful precise alignment data.

As seen from Fig.6 and Fig.7, the cross-plane effects between the horizontal and vertical motion are considered to be very small but the repeatability of the BPM readings are also essential. In spite of the large offset as in the present study, the linear relation between the offset and BPM reading indicates that the non-linear effect is very small even under the sextupole correction to the chromaticity.

REFERENCES

- [1] K. Endo et al, Algorithm for beam based alignment," Proc. 4-th Int. Workshop on Acc. Alignment, Tsukuba, 1995, pp.427-343
- [2] K. Endo, "Preliminary Orbit Measurement for Beam-Based Alignment," Proc. of EPAC96, Barcelona, 1996, pp.1657-9.
- [3] H. Wiedemann, "Particle Accelerator Physics," Springer-Verlag, 1993.
- [4] K. Endo, H. Fukuma, A. Kabe, Ta. Kubo, To. Kubo, N. Kumagai and Y. Takeuchi, "Magnet and Power Supply Systems for the TRISTAN Accumulation Ring," KEK Internal 82-10, 1982.