

Series 44 Ball Valves

*3-piece ball valves designed to meet
all requirements of ANSI B16.34*

THE NEW SERIES 44:

A quantum advance in ball valve durability, cycle life, leak tightness and automation.

Worcester's Series 44 three-piece ball valves, for many years the most respected ball valve design in the industry, are now better than ever. A major research, design, and testing program brings you a new valve, designed to ANSI B16.34 specifications with advanced seal technology and body mount bracket design. This means a very strong, tough valve that can handle pressure and unforeseen piping strains with a stem seal that extends operational cycle life and a standardized overall design that keeps parts inventory to a minimum. Then there's documentation. B16.34 means complete traceability of assembly and testing procedures, heat codes, and foundry identification. Full CMTRS (Certified Material Test Reports) on pressure vessel parts are optionally available. Valve identification is provided on a stainless steel nameplate meeting MSS SP-25.

High Performance

An improved stem seal design, consisting of live-loaded PEEK and Polyfill® thrust bearings and seals, significantly increases valve cycle life over conventional ball valves and extends time between adjustments. In manual valves, the two spring washers are compressed by two retaining nuts. A single Nylon-insert locking nut and four spring washers are used on automated valves.

Body Mounted Actuator Design

Actuators for Worcester's Series 44 three-piece valves are mounted on rigid, precisely machined, box-style brackets bolted to the valve center section. This brings a number of advantages to the valve user:

- Actuator loads are on the valve body;
- Actuators and brackets can be removed for service without affecting valve or piping integrity;
- Easy access for stem seal adjustment;
- Inventory simplification. Mounting brackets are common to three-piece and equivalent flanged valves.

STEM SEALS

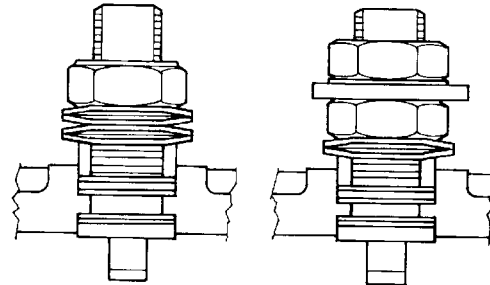

Automated Valve

Manual Valve



1 1/4"-2"



1/4"-1"

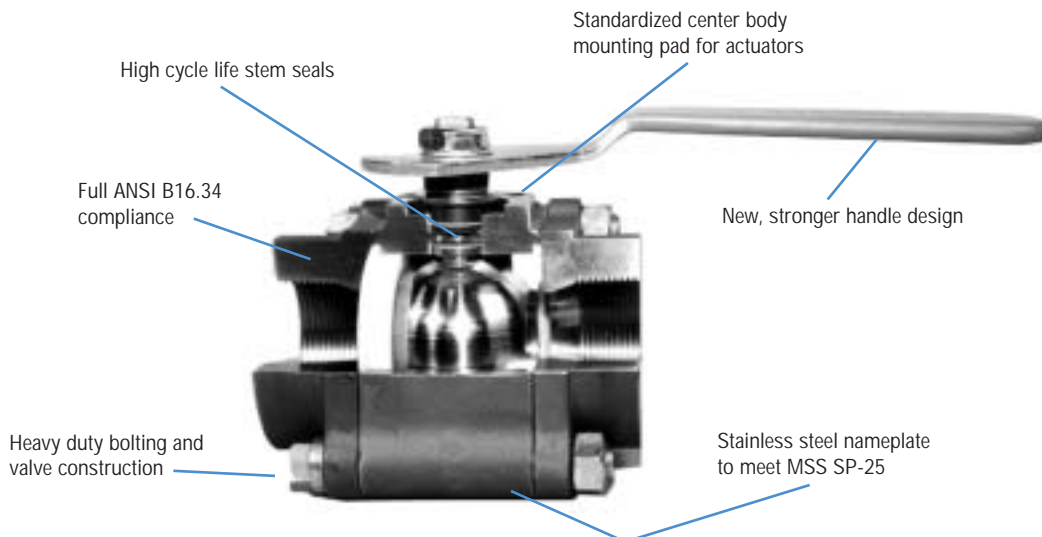

MULTIPLE END CONNECTIONS, SEAT AND SEAL COMBINATIONS

Available through a nationwide network of distributors, Series 44 quarter-turn ball valves and replacement parts are stocked and ready to be adapted to each individual application.

Features which make this tough, reliable ball valve so unique include tight shut-off, smooth two-way flow, advanced seat materials, a variety of interchangeable end connections, swing away three-piece construction, and a design ready for automation.

A variety of pipe ends, including socket weld, screw ends, butt weld or any combination of these, enables Series 44 valves to be adapted to fit standard and more unusual piping situations. **Series 44 (V67) valves can also be welded in place, fully assembled with "G" graphite-coated 316 stainless steel body seals and reinforced TFE, Polyfill, or High-per Fill® seats.**

The range of Worcester's seat materials is unmatched and includes Buna, Neoprene, TFE, Reinforced TFE, Polyfill, Lubetal™, High-per Fill and UHMWPE. These seats easily handle a great majority of industrial fluids with temperatures from -50°F to +600°F including steam, chemicals, petrochemicals, petroleum products, caustics and fluids containing solids, fibrous or abrasive materials.



SWING-OUT DESIGN FOR EASY MAINTENANCE

The Series 44 is especially well suited for use in piping systems where line breaks are required and total entry into the line is necessary. The center section can swing out, eliminating the need to cut a valve out of line and having to replace both the valve and the pipe. Because of this design, the seats, seals and ball can all be replaced quickly and easily without disturbing pipe alignment. Acting as both a valve and a union, the Series 44 eliminates the need for a separate union.



TIGHT SHUTOFF AND BI-DIRECTIONAL SEALING

Worcester's three-piece ball valves are designed to seal bi-directionally against resilient seats. Patented relief slots assist in downstream sealing and reduce torque. The ball is forced to the downstream side under pressure and forced against the downstream seat to effect and maintain a seal. Consequently, the valve will give bubble-tight shut-off throughout a long in-service life even with seats of relatively non-resilient materials such as TFE or Polyfill. The seats are also designed to perform a wiping action during each cycle—cleaning foreign materials off both the seat and ball, assuring leak-tight sealing.

The downstream sealing of Worcester's three-piece valves overcomes the two most common difficulties in the use of conventional ball valves: seat damage and high operating torque. A hole in the stem slot prevents any possibility of damage due to trapped cavity pressure when the ball is open. An optional ball cavity vent is available for specific applications. The Worcester design results in smoother, more efficient valve operation.

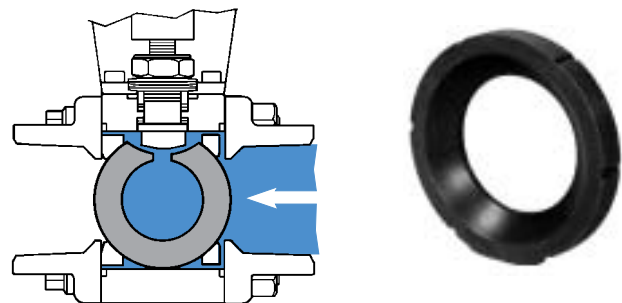

AUTOMATION

Worcester offers a complete line of pneumatic and electric automation packages for Series 44 valves. Both electric and pneumatic packages are offered for on/off or proportional control. Available options include:

FOR PNEUMATIC

- Failsafe operation
- End and top mounted limit switches
- Proximity switches
- Single and double acting pneumatic and electropneumatic positioners
- Pulsair® zero air bleed loop powered positioner
- ACCESS™ integral solenoid and limit switch packages

FOR ELECTRIC

- TYPE 4, 4x, 7 and 9 enclosures
- Remote position indication
- Electronic positioner
- Single loop, PID controller
- Computer interface
- Many more options for today's computer control applications.

SPECIFICATIONS

Series 44 Ball Valves

Valve Sizes: ¼", ⅜", ½", ¾", 1", 1¼", 1½", 2"

Valve Body Pressure Rating For Carbon Steel, Stainless Steel,

Alloy 20 Valves: ANSI Class 600

¼" – 2"—Carbon Steel	1480 psi
¼" – 2"—Stainless Steel	1440 psi
¼" – 2"—Alloy 20®	1200 psi

Valve Body Pressure Rating for Brass Valves:

¼" – 1"—1500 psi
1¼" – 2"—1000 psi

This is the body pressure rating. Seat selection may lower the valve pressure rating. See page 5. Example: A ¾" Series 44 brass valve has a rating of 1500 psi at 70°F. Selection of TFE seats, operating at a fluid temperature of 160°F, limits total allowable pressure in the valve to 800 psi.

Body and Pipe End Materials:

Brass, Carbon Steel, 316 Stainless Steel, Alloy 20
See page 6 for material specifications

Ball: Brass, 316 Stainless Steel, Monel®, Alloy 20, Hastelloy C®

Design Specifications:

ANSI B16.34
ANSI B16.25 - Butt weld ends (weld end preparation)
ANSI B16.11
ANSI B1.20.1 - NPT pipe threads
MSS SP-25 - Valve marking
MSS SP-72 - Socket weld ball valves
NACE - MRO I-75 1984 Rev. Category 3

Seats: Buna, Neoprene, TFE, glass-reinforced TFE, UHMWPE (ultra high molecular weight polyethylene), Polyfill (carbon, graphite filled TFE), High-per Fill, Lubetal

Body Seals, Choice of:

Buna, Neoprene, Viton®, EPDM, TFE, UHMWPE,
TFE coated 316 S.S., graphite coated 316 S.S.

Seals & Thrust Bearings:

PEEK, Graphite and Polyfill
See page 6 for individual parts identification and variations.

Temperature Range:

Dependent upon seal and seat choice, will operate from -50°F to +600°F.

Pressure Range: Valves will operate from 1 micron absolute to +1480 psi.

Seat/Seal Leakage:

Standard valves, less than 1 x 10⁻⁶ cc He/sec in board and through (bubble-tight is 1 x 10⁻⁴ cc He/sec). With preparation, leakage will be less than 2 x 10⁻⁹ cc He/sec. All valves 100% tested to bubble-tight standards.

Optional External Valve Trim:

300 Series stainless steel external components are available as an option on brass and carbon steel valves. They are standard on stainless steel and Alloy 20 valves.

S-7:

Complete S.S. trim: handle, handle nut, lock washer, retaining nut, Belleville washers, body bolts, nuts, stop pin.

Variations (V-numbers): Listing of V-Number Descriptions

V3	Upstream Relief Hole
V5	Hydrostatic Testing
V6	Source Inspection
V17	Grounding Thrust bearing
V20	Oxygen Service
V32	Oval Handle
V33	Oxygen Service without Source Inspect.
V36	Certificate of Compliance
V37	Certificate of Compliance and Hydro Testing
V38	Assemble without Lubricant
V46	Silicon-free Lubricant
V48	Extended Lever Handle
V58	B16.34 Compliance
V59	Extended Oval Handle
V60	OSHA Lockout
V66	Certificate of Compliance, European Valve Orders
V67	Weld-in-Place Valves

SPECIAL SERVICE AND APPROVALS

Underwriter Laboratory Listed

- Flammable liquid shut-off (YRBX)
- Gas shut-off (YRPV)
- LP gas shut-off (YSDT)
- Anhydrous ammonia shut-off (YQAR)
- Compressed gas shut-off, including oxygen (YQNZ)
- Trim and Drain Valves (VQGU)

Factory Mutual Approval for:

- Fire Protection Systems (sprinkler systems, alarm check, dry pipe, deluge valve)
- Gas and Oil Safety Shut-off

Consult Worcester Controls when ordering approved valves.

SEAT PRESSURE/TEMPERATURE RATINGS

- Maximum Temperature for Seals:
 - UHMWPE: 200°F
 - Buna: 250°F
 - TFE: 400°F
 - TFE coated S.S.: 650°F
 - Neoprene: 250°F
 - EPR: 350°F
 - Viton: 450°F
 - Graphite coated S.S.: 1000°F
- "R" (Reinforced TFE) and "P" (Polyfill) seats may be used up to a maximum of 1480 psig as shown. Some decrease in optimum seat life may be expected in some cases above 1000 psig.
- TFE body seals are limited to 200°F temperature swings. (Thermal cycles)
- For high-pressure applications to 3000 psi, Worcester recommends the Series 4 three-piece valves with Lubetal seats. Refer to brochure no. PB-4. For pressures to 5000 psi, specify the Series H44 Dyn-O-Miser® valve with Lubetal or High-per Fill seats. Refer to brochure no. PB-950.

CAUTION: For high pressure media that are highly flammable, explosive or toxic, consult Worcester Controls.

NOTE: Standard Worcester valves are assembled with silicon based break-in lubricant. For other options, consult your distributor or Worcester Controls.

OPERATING TORQUE FOR AUTOMATED VALVES

Valve Torque:

Before the actuator can be sized for any given valve application, the operating torque required for the valve must be determined. The operating torque of the ball valve is influenced by a number of factors—some are design and materials related, others are application (service conditions) related. Design related factors include the type and material of the valve seats, while application factors include system pressure, media and frequency of operation.

For complete valve operating torque data, refer to Worcester's Actuator Sizing Manual (ASM). This eight page publication explains the concept of valve torque, presents torque curves for each seat material, and provides correction factors for media and the type of service such as on-off operation, cycle frequency, etc.

Other Approvals

- U.S.C.G. - United States Coast Guard
- U.S.D.A. - United States Dept. of Agriculture

Valve Size	CV	Equivalent Length of Sched. 40 Pipe (ft.)
1/4", 3/8"	8	0.9
1/2"	8	3.1
3/4"	12	6.3
1"	32	3.1
1 1/4"	46	6.3
1 1/2"	82	4.3
2"	120	7.5

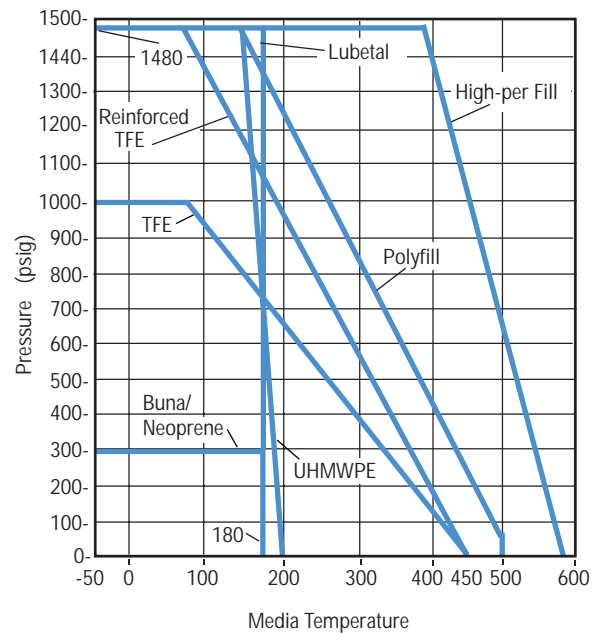

PARTS IDENTIFICATION

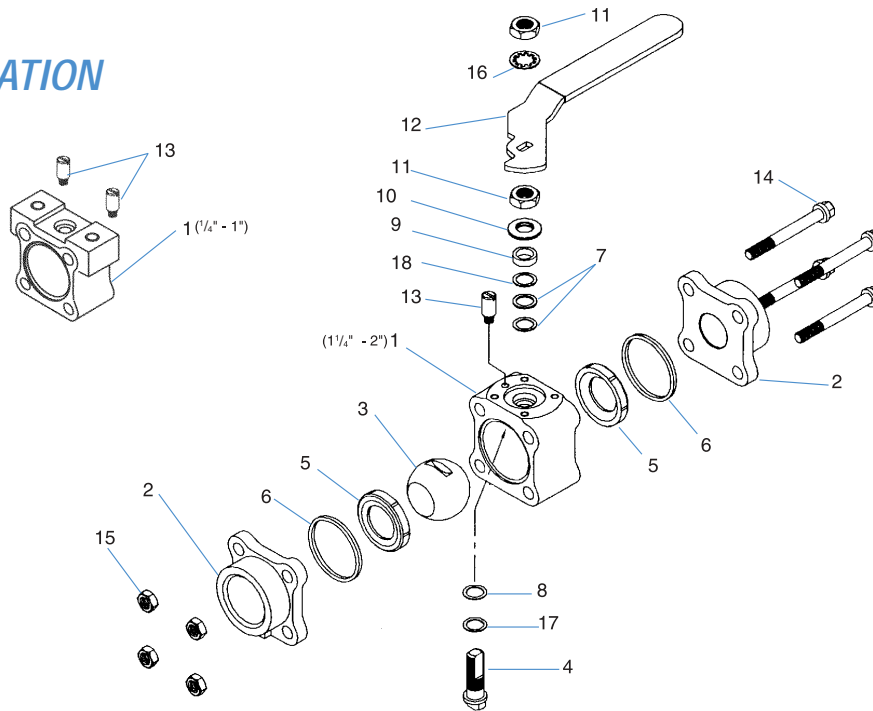

No.	Part	Qty	Material
1	Valve Body	1	Brass ASTM B283 Gr. C3770 Forged Carbon Steel ASTM A105 Forged or ASTM A216 Gr. WCB Cast Stainless Steel ASTM A351 Gr. CF8M Cast Alloy 20 ASTM A351 Gr. CN7M Cast
2	Pipe Ends**	2	Same as body material except stainless weld ends and Tri-Clamp® are Grade CF3M
3, 4	Ball and Stem Combinations	1	Brass ASTM B16 Gr. H02 Hard Chrome Plated ball; ASTM B16 Stem Stainless Steel ASTM A479 Gr. 316 S.S. Alloy 20 ASTM B473 Monel ASTM B164 Gr. N04400 Hastelloy C ASTM B574 Gr. N10276
5	Seats	2	Buna, Neoprene, TFE, Reinforced TFE, Polyfill, UHMWPE, High-per Fill, Lubetal
6	Body Seals	2	Buna, Neoprene, TFE, EPR, Viton, TFE Coated, 316 S.S. "S" gasket, UHMWPE, Graphite Coated 316 S.S. "S" Gasket
7	Stem Seal	2	Polyfill (UHMWPE with UHMWPE seats; Graphite with High-per Fill seats)
8	Thrust Bearing	1	Polyfill (UHMWPE with UHMWPE seats; PEEK with High-per Fill seats; Delrin with Lubetal seats)

No.	Part	Qty	Material
9	Stem Seal Follower	1	316 Stainless Steel
10	Belleville Washers†	2	Carbon Steel: Zinc Plated ANSI 301 Stainless Steel
11	Retaining Nut†	2	Carbon Steel: Zinc Plated; ANSI 300 Series Stainless Steel: Zinc Plated
12	Handle Assembly†	1	Carbon Steel: Zinc Plated ANSI 300 Series Stainless Steel Vinyl Covered
13	Stop Pin†	1 or 2	Carbon Steel: Zinc Plated S.S. ASTM A276 300 Series
14, 15	Body Bolts and Nuts†	4	Carbon Steel and Brass Valves Bolt — A193 Gr B7; Zinc Plated Nut — ASTM A194 Gr. 2H; Zinc Plated Stainless Steel and Alloy 20 Valves Bolt — ASTM A193 Gr. B8: Zinc Plated Nut — ASTM A194 Gr. 8 S7 Stainless Steel Externals Option Bolt — ASTM A193 Gr. B8: Zinc Plated Nut — ASTM A194 Gr. 8
16	Lockwasher†	1	Carbon Steel: Zinc Plated Stainless Steel 300 Series
17	Thrust Bearing Protector*	1	PEEK (UHMWPE with UHMWPE seats; Delrin with Lubetal seats)
18	Seal Protector*	1	PEEK
19	Name Plate (not shown)	1	Stainless Steel ANSI 304

†Stainless Steel standard on Series 4466 and 44AA valves.

*Oxygen Service Valves use Polyfill in place of PEEK.

**All stainless steel weld ends in 316L.

DIMENSIONS

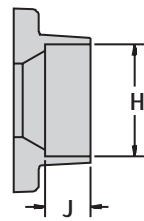
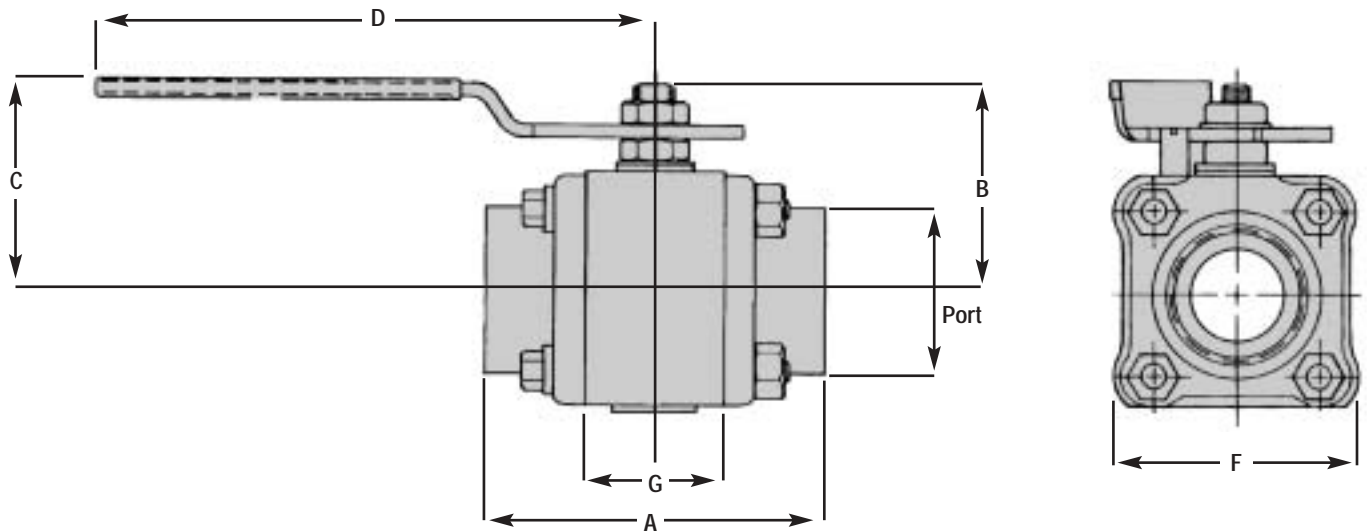

SOCKET WELD SW

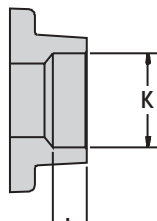

O.D. TUBE END SWO

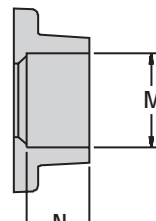

TUBE END TE
K, L, OR M
(Copper Tube)

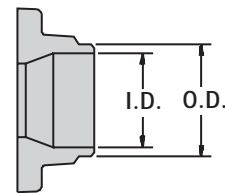

BUTT WELD BW
SCH. 5, 10 (Stainless Steel)
SCH. 40, 80 (Carbon Steel)

*The inside configuration of O.D. tube pipe ends varies by size and material.

*For XBO and TC ends, call Worcester Controls Corporation.

Valve Size	A	B	C	D	F	G	Socket Weld SW		O.D. Tube End SWO		O.D. Tube End TE		Butt Weld Stainless Steel				Butt Weld Carbon Steel				Port	Approx. Weight lb. (kg)
							H	J	K	L	M	N	BW5 Sch. 5		BW1 Sch. 10		BW4 Sch. 40		BW8 Sch. 80			
													O.D.	I.D.	O.D.	I.D.	O.D.	I.D.	O.D.	I.D.		
1/4"	2.54 (64.5)	1.55 (39.4)	1.76 (44.7)	5.53 (140)	1.75 (44.5)	.813 (20.7)	.555 (14.1)	.44 (11.2)	—	—	.378 (9.6)	.37 (9.4)	—	—	.55 (14.0)	.406 (10.3)	.550 (14.0)	.344 (8.7)	—	—	.44 (11.2)	1.10 (.50)
3/8"	2.54 (64.5)	1.55 (39.4)	1.76 (44.7)	5.53 (140)	1.75 (44.5)	.813 (20.7)	.690 (17.5)	.44 (11.2)	—	—	.503 (12.8)	.44 (11.2)	—	—	.67 (17.0)	.547 (13.9)	.670 (17.0)	.516 (13.1)	—	—	.44 (11.2)	1.10 (.50)
1/2"	2.54 (64.5)	1.55 (39.4)	1.76 (44.7)	5.53 (140)	1.75 (44.5)	.813 (20.7)	.855 (21.7)	.44 (11.2)	.510 (13.0)	.44 (11.2)	.628 (15.6)	.56 (14.2)	.840 (21.3)	.710 (18.0)	.84 (21.3)	.672 (17.1)	.840 (21.3)	.625 (15.9)	.840 (21.3)	.550 (14.0)	.44 (11.2)	1.10 (.50)
3/4"	2.76 (70.1)	1.64 (41.7)	1.86 (47.2)	5.53 (140)	2.00 (50.8)	.969 (24.6)	1.065 (27.1)	.56 (14.2)	.760 (19.3)	.56 (14.2)	.878 (22.3)	.81 (20.6)	1.05 (26.7)	.920 (23.4)	1.05 (26.7)	.875 (22.2)	1.05 (26.7)	.812 (20.6)	1.05 (20.6)	.753 (26.7)	.56 (14.2)	1.75 (.79)
1"	3.66 (93.0)	2.19 (55.6)	2.28 (57.9)	6.53 (166)	2.38 (60.5)	1.25 (31.8)	1.330 (33.8)	.72 (18.3)	1.01 (25.7)	.56 (14.2)	1.129 (28.7)	.97 (24.5)	1.31 (33.3)	1.18 (30.1)	1.31 (33.3)	1.09 (27.8)	1.31 (33.3)	1.05 (26.6)	1.31 (33.3)	.957 (24.3)	.81 (20.6)	3.10 (1.41)
1 1/4"	4.16 (105)	2.38 (60.5)	2.47 (62.7)	6.53 (166)	2.70 (68.6)	1.63 (41.3)	1.675 (42.5)	.72 (18.3)	1.26 (32.0)	.62 (15.8)	1.379 (35.0)	1.03 (26.2)	1.66 (42.2)	1.53 (38.9)	1.66 (42.2)	1.44 (36.5)	1.66 (42.2)	1.38 (35.1)	1.66 (42.2)	1.27 (32.3)	1.00 (25.4)	4.50 (2.04)
1 1/2"	4.50 (114)	2.88 (73.2)	2.83 (71.9)	8.03 (204)	3.16 (80.3)	1.91 (48.4)	1.915 (48.6)	.72 (18.3)	1.51 (38.4)	.62 (15.8)	1.629 (41.4)	1.15 (29.2)	1.91 (48.5)	1.77 (45.0)	1.91 (48.5)	1.67 (42.5)	1.91 (48.5)	1.59 (40.5)	1.91 (48.5)	1.52 (38.6)	1.25 (31.8)	6.20 (2.82)
2"	4.94 (126)	3.06 (77.7)	3.02 (76.7)	8.03 (204)	3.56 (90.4)	2.22 (56.3)	2.406 (61.1)	.84 (21.3)	2.01 (51.1)	.67 (17.0)	2.129 (54.1)	1.15 (29.2)	2.38 (60.5)	2.24 (57.0)	2.38 (60.5)	2.15 (54.5)	2.38 (60.5)	2.06 (52.4)	2.38 (60.5)	1.93 (48.9)	1.50 (38.1)	9.50 (4.31)

Dimensions are for reference only. For tolerances, consult Worcester Controls.

How to Order*

Valve Size	Options	Product Series	Body, Pipe Ends	Ball & Stem	Seats	Body Seals	Ends
1/4"	Blank - Built with lever handle	44	1- Brass	1- Brass (chrome plated)	B- Buna	B- Buna	SE - Screwed Pipe Ends (NPT) Any Sch. Pipe† Carbon Steel Stainless Steel Alloy 20
3/8"	E - No handle valve built for automation		4- Carbon Steel	4- Carbon Steel (chrome plated)	N- Neoprene	N- Neoprene	Butt Weld (BW) ends: BW1 - Stainless Steel, Sch. 10 BW4 - Carbon Steel, Sch. 40 BW4 - Stainless Steel, Sch. 40 BW5 - Stainless Steel, Sch. 5 BW8 - Carbon Steel, Sch. 80
1/2"			6- 316 S.S.		T- TFE	T- TFE	
3/4"	A - No handlett		A- Alloy 20	6- 316 S.S.	R- Reinforced TFE	E- EPR	
1"	B - No handlett			7- Monel	P- Polyfill	V- Viton	
1 1/4"	G - Stem Grounding Spring			A- Alloy 20	U- UHMWPE	M- TFE Coated 316 S.S.	TE - Solder/Sweat Ends Brass - Type K, L, or M copper tube
1 1/2"	K - Locking Handle			C- Hastelloy C	X- High-per Fill	G- Graphite Coated 316 S.S.	SW - Socket Weld Ends Any Sch. Pipe† Carbon Steel Stainless Steel Alloy 20
2"	V - Vacuum Service Prep X - Oxygen Service Prep				Y- Lubetal	U- UHMWPE	SWO - Socket Weld Ends O.D. Tube S.S.(not available in 1/4" and 3/8" sizes) TC - Quick Disconnect XBO - Extended Butt Weld NP - No Pipe Ends, body bolts and nuts

*TO ORDER V67 WELD-IN-PLACE VALVES: Series 44 valves with "G" body seals and seats of Reinforced TFE (R), Polyfill (P), or High-per Fill (X), may be welded in a line in the assembled condition.

**Variations (V-Numbered Options) see page 4 for listing. Leave blank if no variations.

Add V58 to ordering code if full B16.34 compliance is required.

Full ANSI B16.34 compliance requires a hydrotest and certified material test reports.

ORDERING EXAMPLE: 1/4" Series 44 valve with 316 S.S. body, ball and stem, TFE seats and seals, and socket weld ends.

EXTERNALS: Externals, including handles, are normally constructed of zinc plated carbon steel. Handles are vinyl coated. When required, the body bolts, nuts, retaining nut, handle nut, lock-washer, stop pin and handle are also available in stainless steel by special order (S-7 suffix in ordering code), and come standard when ordering 4466 Stainless Steel or 44AA Alloy 20 valves.

†All IPS schedules of stainless, carbon and alloy steel pipe, S.P.S. copper pipe and red brass pipe.

††To order a Series 44 valve for use with:

34 or 36 actuators, use prefix ordering code "A". EXAMPLE: 1" A 4446 6 PMSE

39 or 75 actuators, use prefix ordering code "B".

Caution: Ball valves can retain pressurized media in the body cavity when closed. Use care when disassembling. Always open valve to relieve pressure prior to disassembly. Due to continuous development of our product range, we reserve the right to alter the product specifications and information contained in this brochure as required.

Monel® is a registered trademark of Inco Alloys International.

Hastelloy® is a registered trademark of Haynes International.

Tri-Clamp® is a registered trademark of Ladish Co.

Viton® is a registered trademark of E.I. duPont.

Polyfill® is a registered trademark of Worcester Controls.

Lubetal™ is a trademark of Garlock, Inc.

ACCESS™ is a trademark of Worcester Controls.

Alloy 20® is a trademark of CRS Holdings, Inc.

Pulsair® is a registered trademark of Worcester Controls.

High-per Fill® is a registered trademark of Worcester Controls.

Dyn-O-Miser® is a registered trademark of Worcester Controls.

Worcester is a registered trademarks of Flowserve Corporation.

Invensys™ is a trademark of BTR Siebe plc.

Flowserve Corporation has established industry leadership in the design and manufacture of its products. When properly selected, this Flowserve product is designed to perform its intended function safely during its useful life. However, the purchaser or user of Flowserve products should be aware that Flowserve products might be used in numerous applications under a wide variety of industrial service conditions. Although Flowserve can (and often does) provide general guidelines, it cannot provide specific data and warnings for all possible applications. The purchaser/user must therefore assume the ultimate responsibility for the proper sizing and selection, installation, operation, and maintenance of Flowserve products. The purchaser/user should read and understand the Installation Operation Maintenance (IOM) instructions included with the product, and train its employees and contractors in the safe use of Flowserve products in connection with the specific application.

While the information and specifications contained in this literature are believed to be accurate, they are supplied for informative purposes only and should not be considered certified or as a guarantee of satisfactory results by reliance thereon. Nothing contained herein is to be construed as a warranty or guarantee, express or implied, regarding any matter with respect to this product. Because Flowserve is continually improving and upgrading its product design, the specifications, dimensions and information contained herein are subject to change without notice. Should any question arise concerning these provisions, the purchaser/user should contact Flowserve Corporation at any one of its worldwide operations or offices.

For more information about Flowserve Corporation, contact www.flowserve.com or call USA 1-800-225-6989.

FLOWSERVE CORPORATION
FLOW CONTROL DIVISION
1978 Foreman Drive
Cookeville, Tennessee 38501 USA
Phone: 931 432 4021
Facsimile: 931 432 5518